

**SAMSUNG TECHWIN**

# **NETWORK CAMERA**

User Manual

SNP-3120/  
3120V/3120VH



**SAMSUNG**

CE

**SAMSUNG**

# Network Camera

## User Manual

---

### Copyright

©2011 Samsung Techwin Co., Ltd. All rights reserved.

### Trademark

 **SAMSUNG TECHWIN** is the registered logo of Samsung Techwin Co., Ltd.  
The name of this product is the registered trademark of Samsung Techwin Co., Ltd.

Other trademarks mentioned in this manual are the registered trademark of their respective company.

### Restriction

Samsung Techwin Co., Ltd shall reserve the copyright of this document. Under no circumstances, this document shall be reproduced, distributed or changed, partially or wholly, without formal authorization of Samsung Techwin.

### Disclaimer

Samsung Techwin makes the best to verify the integrity and correctness of the contents in this document, but no formal guarantee shall be provided. Use of this document and the subsequent results shall be entirely on the user's own responsibility. Samsung Techwin reserves the right to change the contents of this document without prior notice.

### Warranty

If the product does not operate properly in normal conditions, please let us know. Samsung Techwin will resolve the problem for free of charge. The warranty period is 3 years. However, the followings are excluded:

- If the system behaves abnormally because you run a program irrelevant to the system operation.
- Deteriorated performance or natural worn-out in process of time

❖ **Design and specifications are subject to change without prior notice.**

❖ **The default password can be exposed to a hacking thread so it is recommended to change the password after installing the product.**

**Note that the security and other related issues caused by the unchanged password shall be responsible for the user.**

## IMPORTANT SAFETY INSTRUCTIONS

---

1. Read these instructions.
2. Keep these instructions.
3. Heed all warnings.
4. Follow all instructions.
5. Do not use this apparatus near water.
6. Clean only with dry cloth.
7. Do not block any ventilation openings, Install in accordance with the manufacturer's instructions.
8. Do not install near any heat sources such as radiators, heat registers, stoves, or other apparatus (including amplifiers) that produce heat.
9. Do not defeat the safety purpose of the polarized or grounding-type plug. A polarized plug has two blades with one wider than the other. A grounding type plug has two blades and a third grounding prong. The wide blade or the third prong are provided for your safety, If the provided plug does not fit into your outlet, consult an electrician for replacement of the obsolete outlet.
10. Protect the power cord from being walked on or pinched particularly at plugs, convenience receptacles, and the point where they exit from the apparatus.
11. Only use attachments/ accessories specified by the manufacturer.
12. Use only with the cart, stand, tripod, bracket, or table specified by the manufacturer, or sold with the apparatus. When a cart is used, use caution when moving the cart/apparatus combination to avoid injury from tip-over.
13. Unplug this apparatus during lightning storms or when unused for long periods of time.
14. Refer all servicing to qualified service personnel. Servicing is required when the apparatus has been damaged in any way, such as power-supply cord or plug is damaged, liquid has been spilled or objects have fallen into the apparatus, the apparatus has been exposed to rain or moisture, does not operate normally, or has been dropped.



## WARNING

TO REDUCE THE RISK OF FIRE OR ELECTRIC SHOCK, DO NOT EXPOSE THIS PRODUCT TO RAIN OR MOISTURE. DO NOT INSERT ANY METALLIC OBJECT THROUGH THE VENTILATION GRILLS OR OTHER OPENINGS ON THE EQUIPMENT.

Apparatus shall not be exposed to dripping or splashing and that no objects filled with liquids, such as vases, shall be placed on the apparatus.

## CAUTION

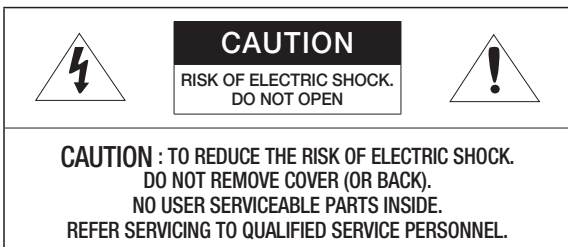

## EXPLANATION OF GRAPHICAL SYMBOLS



The lightning flash with arrowhead symbol, within an equilateral triangle, is intended to alert the user to the presence of “dangerous voltage” within the product’s enclosure that may be of sufficient magnitude to constitute a risk of electric shock to persons.



The exclamation point within an equilateral triangle is intended to alert the user to the presence of important operating and maintenance (servicing) instructions in the literature accompanying the product.

When used outside of the U.S., it may be used HAR code with fittings of an approved agency is employed.

## CAUTION

These servicing instructions are for use by qualified service personnel only. To reduce the risk of electric shock do not perform any servicing other than that contained in the operating instructions unless you are qualified to do so.

The BNC Out terminal of the product is provided for easier installation, and is not recommended for monitoring purposes.

If you keep the BNC cable connected, a risk of lightening may cause damage or malfunction to the product.

Please use the input power with just one camera and other devices must not be connected.









Do not expose the product to the direct airflow from an air conditioner. Otherwise, it may cause moisture condensation inside the Clear Dome due to temperature difference between internal and external of the dome camera.

If you install this product in a low-temp area such as inside a cold store, you must seal up the wiring pipe with silicon, so that the external air can not flow inside the housing.

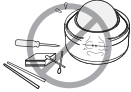
Otherwise, external high, humid air may flow inside the housing, pooling moisture or vapor inside the product due to a difference between internal and external temperature.

# overview

Please read the following recommend safety precautions carefully.

<p>Do not place this apparatus on an uneven surface.</p> 	<p>Do not install on a surface where it is exposed to direct sunlight, near heating equipment or heavy cold area.</p> 
<p>Do not place this apparatus near conductive material.</p> 	<p>Do not attempt to service this apparatus yourself.</p> 
<p>Do not place a glass of water on the product.</p> 	<p>Do not install near any magnetic sources.</p> 
<p>Do not block any ventilation openings.</p> 	<p>Do not place heavy items on the product.</p> 

User's Manual is a guidance book how to use the products

The meaning of the using sign in the book is following

- Reference : In case of providing information for helping of product's usages
- Notice : If there's any possibility to occur any damages for the goods and human caused by not following the instruction
- ✖ Please read this manual for the safety before using of goods and keep it in the safe place.



This equipment has been tested and found to comply with the limits for a Class A digital device, pursuant to part 15 of the FCC Rules. These limits are designed to provide reasonable protection against harmful interference when the equipment is operated in a commercial environment.

This equipment generates, uses, and can radiate radio frequency energy and, if not installed and used in accordance with the instruction manual, may cause harmful interference to radio communications. Operation of this equipment in a residential area is likely to cause harmful interference in which case the user will be required to correct the interference at his own expense.



Samsung Techwin cares for the environment at all product manufacturing stages, and is taking measures to provide customers with more environmentally friendly products.

The Eco mark represents Samsung Techwin's devotion to creating environmentally friendly products, and indicates that the product satisfies the EU RoHS Directive.



#### Correct Disposal of This Product (Waste Electrical & Electronic Equipment)

(Applicable in the European Union and other European countries with separate collection systems)

This marking on the product, accessories or literature indicates that the product and its electronic accessories (e.g. charger, headset, USB cable) should not be disposed of with other household waste at the end of their working life. To prevent possible harm to the environment or human health from uncontrolled waste disposal, please separate these items from other types of waste and recycle them responsibly to promote the sustainable reuse of material resources.

Household users should contact either the retailer where they purchased this product, or their local government office, for details of where and how they can take these items for environmentally safe recycling.

Business users should contact their supplier and check the terms and conditions of the purchase contract. This product and its electronic accessories should not be mixed with other commercial wastes for disposal.

## CONTENTS

---

<b>OVERVIEW</b>	<b>3</b>	Important Safety Instructions
	<b>10</b>	Product Features
	<b>10</b>	Recommended PC Specifications
	<b>10</b>	Recommended SDHC/SD Memory Card Specifications
	<b>11</b>	What's Included
	<b>13</b>	At a Glance
<b>INSTALLATION &amp; CONNECTION</b>	<b>18</b>	DIP Switch Setting
	<b>28</b>	Installation (SNP-3120)
	<b>32</b>	Installing with accessories (Sold Separately)
	<b>34</b>	Installation (SNP-3120V)
	<b>37</b>	Installation (SNP-3120VH)
	<b>41</b>	Inserting/Removing an SD Memory Card
	<b>42</b>	Memory Card Information (Not Included)
	<b>43</b>	Connecting with other Device
<b>NETWORK CONNECTION AND SETUP</b>	<b>46</b>	Connecting the Camera Directly to Local Area Networking
	<b>47</b>	Connecting the Camera Directly to a DHCP Based DSL/Cable Modem
	<b>48</b>	Connecting the Camera Directly to a PPPoE Modem
	<b>49</b>	Connecting the Camera to an IP Router with the PPPoE/Cable Modem
	<b>50</b>	Buttons used in IP Installer
	<b>51</b>	Static IP Setup
	<b>54</b>	Dynamic IP Setup
	<b>55</b>	Port Range Forward (Port Mapping) Setup
	<b>57</b>	Connecting to the Camera from a Shared Local PC
	<b>57</b>	Connecting to the Camera from a Remote PC via the Internet



<b>WEB VIEWER</b>	58	Connecting to the Camera
58	59	Login
58	60	Installing Silverlight Runtime
58	62	Using the Live Screen
58	65	Playback
58	66	Playing the backup recordings
<b>CAMERA SETUP</b>	67	Using the Camera Menu
67	67	Camera Setting
67	77	OSD Setting
67	79	Initialize
<b>SETUP SCREEN</b>	80	Setup
80	80	Audio & Video Setup
80	88	Network Setup
80	93	Event Setup
80	99	System Setup
<b>APPENDIX</b>	104	Specification
104	109	Product Overview
104	111	Troubleshooting
104	113	Open Source Announcement
104	115	GPL/LGPL Software License

## PRODUCT FEATURES

---

- **Multi-Streaming**

This network camera can display videos in different resolutions and qualities simultaneously using different CODECs.



- However, MPEG4 video can not be played on a web page. Use CMS software if you want to play the video on a web page.

- **Web Browser-based Monitoring**

Using the Internet web browser to display the image in a local network environment.

- **Alarm**

If an event occurs, the event-related video will be transferred to the email specified by the user or saved to the SD memory, or the event signal will be sent to the Alarm Out port.

- **Intelligent Video Analysis**

Analyzes the event video according to the user-specified rules to recognize the event.

- **ONVIF (Spec 1.02) Compliance**

This product supports ONVIF Core Spec. 1.02.  
For more information, refer to [www.onvif.org](http://www.onvif.org).



Driving network video through global standardization

## RECOMENDED PC SPECIFICATIONS

---

- CPU : Intel(R) Core(TM)2 2.00 GHz or higher
- Operating System : Windows XP, VISTA, 7  
Mac OS
- Resolution : 1280X1024 pixels or higher
- RAM : 1GB or higher
- Web Browser : Internet Explorer 6.0 or higher  
Firefox, Google Chrome, Safari
- Video Memory : 128MB or higher







## RECOMENDED SDHC/SD MEMORY CARD SPECIFICATIONS

---

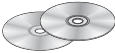



- 2GB ~ 32GB
- To ensure proper recording of video data, we recommend you use a memory card that supports at least read/write speed 10Mbps and Class 6.

## WHAT'S INCLUDED

Please check if your camera and accessories are all included in the product package.

Appearance	Item Name	Quantity	Description	Model Name
	User Manual, Installer S/W DVD, CMS S/W DVD	2		SNP-3120/3120V/ 3120VH
	Quick Guide	1		
	7Pin Terminal Block	1	For communications	
	8Pin Terminal Block	1	For alarm I/O	
	Cable for the testing monitor	1	Used to test the camera connection to a portable display device	
	Audio cable	1		

# overview

Appearance	Item Name	Quantity	Description	Model Name
	Template	1	Product installation guide	SNP-3120
	ASSY-Tapping Screw	4	Used for installation on the wall or ceiling	
	Mount Bracket	1		SNP-3120
	L Wrench	1	Used to remove/fix the dome cover	SNP-3120V/3120VH



- The Test Monitor Cable is connected to a portable displayer and used for testing the camera. If you intend to use it for an actual monitoring camera, use the BNC cable instead.

## AT A GLANCE

### ❖ SNP-3120

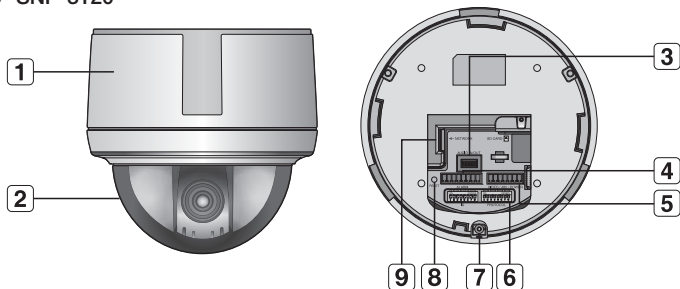

Item	Description
<b>1</b> Main unit	Main unit includes the lens, switch board, PCB boards and screws.
<b>2</b> Dome Cover	Dome cover for the lens and unit protection.
<b>3</b> Audio	Audio I/O port.
<b>4</b> Alarm In / Out terminals	Used to connect alarm in/out terminal block.
<b>5</b> Video, RS-485, Power	Used to connect monitor, RS-485 device or power.
<b>6</b> ID setup switch	Used to setup the camera ID or communication protocol.
<b>7</b> Screw Hole	Used to fix the camera to the wall or ceiling.
<b>8</b> Reset Button	Resets the camera settings to the default. Press and hold it for about 5 seconds to turn off the system indicator and restart the system. <b>!</b> If you reset the camera, the network settings will be adjusted so that DHCP can be enabled. If there is no DHCP server in the network, you must run the IP Installer program to change the basic network settings such as IP address, Subnet mask, Gateway, etc., before you can connect to the network.
<b>9</b> Network port	Used to connect a PoE or LAN cable.

# overview

## ❖ SNP-3120V

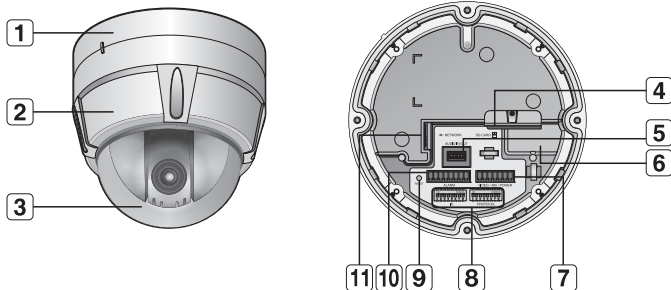

Item	Description
<b>1</b> Surface Mount Bracket	Used to install the camera directly on the ceiling. After separating this cover, mount this bracket on to ceiling.
<b>2</b> Main unit	Main unit includes the lens, switch board, PCB boards and screws.
<b>3</b> Dome Cover	Dome cover for the lens and unit protection.
<b>4</b> SD Memory Card Compartment	Compartment for the SD memory card.
<b>5</b> Audio	Audio I/O port.
<b>6</b> Heater	Activated when the ambient temperature is under 5°C to prevent the dome cover from being covered with frost.
<b>7</b> Video, RS-485, Power	Used to connect monitor, RS-485 device or power.
<b>8</b> ID setup switch	Used to setup the camera ID or communication protocol.
<b>9</b> Reset Button	Resets the camera settings to the default. Press and hold it for about 5 seconds to turn off the system indicator and restart the system. <b>!</b> If you reset the camera, the network settings will be adjusted so that DHCP can be enabled. If there is no DHCP server in the network, you must run the IP Installer program to change the basic network settings such as IP address, Subnet mask, Gateway, etc., before you can connect to the network.
<b>10</b> Alarm In / Out terminals	Used to connect alarm in/out terminal block.
<b>11</b> Network port	Used to connect a PoE or LAN cable.

## ❖ SNP-3120VH

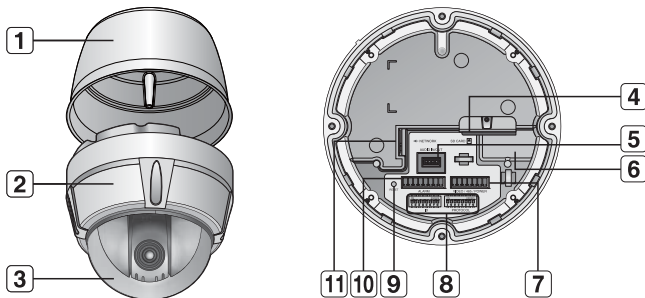

Item	Description
<b>1</b> Sun Shield Housing	Used to protect the main unit from the sunlight.
<b>2</b> Main unit	Main unit includes the lens, switch board, PCB boards and screws.
<b>3</b> Dome Cover	Dome cover for the lens and unit protection.
<b>4</b> SD Memory Card Compartment	Compartment for the SD memory card.
<b>5</b> Audio	Audio I/O port.
<b>6</b> Heater	Activated when the ambient temperature is under 5°C to prevent the dome cover from being covered with frost.
<b>7</b> Video, RS-485, Power	Used to connect monitor, RS-485 device or power.
<b>8</b> ID setup switch	Used to setup the camera ID or communication protocol.
<b>9</b> Reset Button	Resets the camera settings to the default. Press and hold it for about 5 seconds to turn off the system indicator and restart the system. <b>I</b> If you reset the camera, the network settings will be adjusted so that DHCP can be enabled. If there is no DHCP server in the network, you must run the IP Installer program to change the basic network settings such as IP address, Subnet mask, Gateway, etc., before you can connect to the network.
<b>10</b> Alarm In / Out terminals	Used to plug terminal block to connect alarm in/out.
<b>11</b> Network port	Used to connect a PoE or LAN cable.

## ❖ Camera Wiring Interface Board

For the camera wiring, please refer to the picture below. When using coaxial communication, a separate control signal connection is not required.

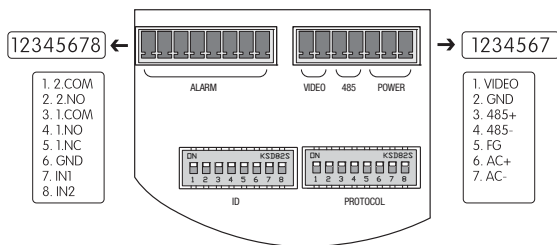

### Controller & Auxiliary Signal Connection

No.	Name	Usage
1	2.COM	Alarm Output 2 (Common)
2	2.NO	Alarm Output 2 (Normal Open)
3	1.COM	Alarm Output 1 (Common)
4	1.NO	Alarm Output 1 (Normal Open)
5	1.NC	Alarm Output 1 (Normal Open)
6	GND	Ground
7	IN1	Alarm Input Sensor Terminal 1
8	IN2	Alarm Input Sensor Terminal 2



## Power, Video & Communication Signal Connection

No.	Name	Usage
1	VIDEO	Video Output
2	GND	Ground
3	485+	Controller Data Line
4	485-	Controller Data Line
5	FG	Field Ground
6	AC	AC 24V
7	AC	AC 24V



- The provided BNC cable's blue line is Video Output, while the black line is the Ground.
- Power supply adaptor (AC) has no polarities.



- The maximum power capacity of the built-in relay is 30V DC/2A, 125V AC/0.5A, and 250V AC/0.25A.
- Connecting the power connector and GND incorrectly to the NC/NO and COM ports may cause a short circuit and fire, damaging the camera.
- When connecting the camera to an external over-rated product, use a separate relay device to ensure proper operation.
- To prevent possible inflow of lightning while in test monitoring, perform the test with the FG terminal grounded.

# installation & connection

## DIP SWITCH SETTING

### How to set up Protocols and ID DIP Switches

You can control various settings of the camera system using the Communication and ID DIP switches. Before installing the product, please set up the DIP switches according to the installation environment.

1. Detach the camera frame from the install base, and place the bottom of the frame toward you as shown in the picture below.
2. Set the switches according to your installation environment. For more detailed setup information, please refer to the chart on the next page.
3. The camera may malfunction if the switches are not fully turned On/Off; please double check the switches before finishing setup.

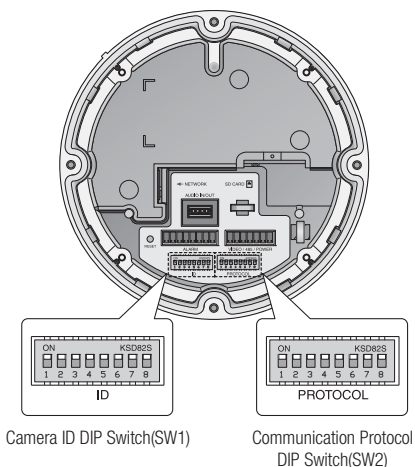

## Communication Protocol DIP Switch Settings (SW2)

Coaxial communication automatically detects signals, and so does not require a separate communication setup process.

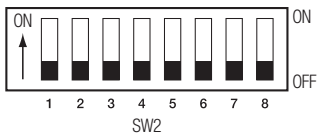

SW2 Pin No.	Purpose
1~4	Protocol Settings
5~6	Baud Rate Settings
7	Response Mode Settings
8	Termination Settings

### ● Protocol Settings

Select a communication protocol for the camera.

No.	Protocol	SW2-#1	SW2-#2	SW2-#3	SW2-#4
1	AUTO DETECT	OFF	OFF	OFF	OFF
2	Samsung-T	OFF	OFF	OFF	ON
3	Pelco-D	OFF	OFF	ON	OFF
4	Pelco-P	OFF	OFF	ON	ON
5	Samsung-E	OFF	ON	OFF	OFF
6	Panasonic	OFF	ON	OFF	ON
7	Vicon	OFF	ON	ON	OFF
8	Honeywell	OFF	ON	ON	ON
9	AD	ON	OFF	OFF	OFF
10	GE	ON	OFF	OFF	ON
11	BOSCH	ON	OFF	ON	OFF
12	Reserved	ON	OFF	ON	ON
13	Reserved	ON	ON	OFF	OFF
14	Reserved	ON	ON	OFF	ON
15	Reserved	ON	ON	ON	OFF
16	Reserved	ON	ON	ON	ON

# installation & connection

## • Baud Rate Settings

Select the transfer speed of a selected communication protocol.

No.	Baud Rate (BPS)	SW2-#5	SW2-#6
1	2,400	ON	ON
2	4,800	ON	OFF
3	9,600	OFF	OFF
4	19,200	OFF	ON

## • Communication Response Settings

Select a communication response method for the camera and controller: Response or No Response.

	Function	ON	OFF
SW2- #7	Response Mode Switch	Response	No Response

## • Termination Settings

To prevent the attenuation of communication signals between the camera and controller, the items at the end of line must be set up with the termination settings.

Camera Input Position	SW2- #8
Termination of Longest Path	ON
On the Path	OFF

- This model is provided with factory defaults of all DIP switches set to OFF. The default settings are shaded in the table.



- To use a third party controller with this product, please contact our After-Sales Service or Technology Department.
- Controls Using Different Protocols

	AD Protocol	VICON Protocol	GE Protocol
Entering Camera OSD	3+Auxiliary ON	IRIS OPEN	IRIS OPEN
Exiting Camera OSD	3+Auxiliary OFF	IRIS CLOSE	IRIS CLOSE
ENTER	IRIS OPEN	IRIS OPEN	IRIS OPEN
ESC	IRIS CLOSE	IRIS CLOSE	IRIS CLOSE

- For more information about the protocols, refer to our official website.

### Camera ID DIP Switch Settings (SW1)

To set up camera IDs, refer to the “**Camera ID Chart**” next.

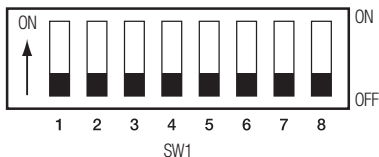

# installation & connection

## • Camera ID Chart

ID	SW1-#1	SW1-#2	SW1-#3	SW1-#4	SW1-#5	SW1-#6	SW1-#7	SW1-#8
1	ON/OFF	OFF	OFF	OFF	OFF	OFF	OFF	OFF
2	OFF	ON	OFF	OFF	OFF	OFF	OFF	OFF
3	ON	ON	OFF	OFF	OFF	OFF	OFF	OFF
4	OFF	OFF	ON	OFF	OFF	OFF	OFF	OFF
5	ON	OFF	ON	OFF	OFF	OFF	OFF	OFF
6	OFF	ON	ON	OFF	OFF	OFF	OFF	OFF
7	ON	ON	ON	OFF	OFF	OFF	OFF	OFF
8	OFF	OFF	OFF	ON	OFF	OFF	OFF	OFF
9	ON	OFF	OFF	ON	OFF	OFF	OFF	OFF
10	OFF	ON	OFF	ON	OFF	OFF	OFF	OFF
11	ON	ON	OFF	ON	OFF	OFF	OFF	OFF
12	OFF	OFF	ON	ON	OFF	OFF	OFF	OFF
13	ON	OFF	ON	ON	OFF	OFF	OFF	OFF
14	OFF	ON	ON	ON	OFF	OFF	OFF	OFF
15	ON	ON	ON	ON	OFF	OFF	OFF	OFF
16	OFF	OFF	OFF	OFF	ON	OFF	OFF	OFF
17	ON	OFF	OFF	OFF	ON	OFF	OFF	OFF
18	OFF	ON	OFF	OFF	ON	OFF	OFF	OFF
19	ON	ON	OFF	OFF	ON	OFF	OFF	OFF
20	OFF	OFF	ON	OFF	ON	OFF	OFF	OFF
21	ON	OFF	ON	OFF	ON	OFF	OFF	OFF
22	OFF	ON	ON	OFF	ON	OFF	OFF	OFF
23	ON	ON	ON	OFF	ON	OFF	OFF	OFF
24	OFF	OFF	OFF	ON	ON	OFF	OFF	OFF
25	ON	OFF	OFF	ON	ON	OFF	OFF	OFF
26	OFF	ON	OFF	ON	ON	OFF	OFF	OFF
27	ON	ON	OFF	ON	ON	OFF	OFF	OFF
28	OFF	OFF	ON	ON	ON	OFF	OFF	OFF
29	ON	OFF	ON	ON	ON	OFF	OFF	OFF
30	OFF	ON	ON	ON	ON	OFF	OFF	OFF
31	ON	ON	ON	ON	ON	OFF	OFF	OFF
32	OFF	OFF	OFF	OFF	OFF	ON	OFF	OFF
33	ON	OFF	OFF	OFF	OFF	ON	OFF	OFF
34	OFF	ON	OFF	OFF	OFF	ON	OFF	OFF
35	ON	ON	OFF	OFF	OFF	ON	OFF	OFF
36	OFF	OFF	ON	OFF	OFF	ON	OFF	OFF
37	ON	OFF	ON	OFF	OFF	ON	OFF	OFF
38	OFF	ON	ON	OFF	OFF	ON	OFF	OFF
39	ON	ON	ON	OFF	OFF	ON	OFF	OFF
40	OFF	OFF	OFF	ON	OFF	ON	OFF	OFF
41	ON	OFF	OFF	ON	OFF	ON	OFF	OFF

ID	SW1-#1	SW1-#2	SW1-#3	SW1-#4	SW1-#5	SW1-#6	SW1-#7	SW1-#8
42	OFF	ON	OFF	ON	OFF	ON	OFF	OFF
43	ON	ON	OFF	ON	OFF	ON	OFF	OFF
44	OFF	OFF	ON	ON	OFF	ON	OFF	OFF
45	ON	OFF	ON	ON	OFF	ON	OFF	OFF
46	OFF	ON	ON	ON	OFF	ON	OFF	OFF
47	ON	ON	ON	ON	OFF	ON	OFF	OFF
48	OFF	OFF	OFF	OFF	ON	ON	OFF	OFF
49	ON	OFF	OFF	OFF	ON	ON	OFF	OFF
50	OFF	ON	OFF	OFF	ON	ON	OFF	OFF
51	ON	ON	OFF	OFF	ON	ON	OFF	OFF
52	OFF	OFF	ON	OFF	ON	ON	OFF	OFF
53	ON	OFF	ON	OFF	ON	ON	OFF	OFF
54	OFF	ON	ON	OFF	ON	ON	OFF	OFF
55	ON	ON	ON	OFF	ON	ON	OFF	OFF
56	OFF	OFF	OFF	ON	ON	ON	OFF	OFF
57	ON	OFF	OFF	ON	ON	ON	OFF	OFF
58	OFF	ON	OFF	ON	ON	ON	OFF	OFF
59	ON	ON	OFF	ON	ON	ON	OFF	OFF
60	OFF	OFF	ON	ON	ON	ON	OFF	OFF
61	ON	OFF	ON	ON	ON	ON	OFF	OFF
62	OFF	ON	ON	ON	ON	ON	OFF	OFF
63	ON	ON	ON	ON	ON	ON	OFF	OFF
64	OFF	OFF	OFF	OFF	OFF	OFF	ON	OFF
65	ON	OFF	OFF	OFF	OFF	OFF	ON	OFF
66	OFF	ON	OFF	OFF	OFF	OFF	ON	OFF
67	ON	ON	OFF	OFF	OFF	OFF	ON	OFF
68	OFF	OFF	ON	OFF	OFF	OFF	ON	OFF
69	ON	OFF	ON	OFF	OFF	OFF	ON	OFF
70	OFF	ON	ON	OFF	OFF	OFF	ON	OFF
71	ON	ON	ON	OFF	OFF	OFF	ON	OFF
72	OFF	OFF	OFF	ON	OFF	OFF	ON	OFF
73	ON	OFF	OFF	ON	OFF	OFF	ON	OFF
74	OFF	ON	OFF	ON	OFF	OFF	ON	OFF
75	ON	ON	OFF	ON	OFF	OFF	ON	OFF
76	OFF	OFF	ON	ON	OFF	OFF	ON	OFF
77	ON	OFF	ON	ON	OFF	OFF	ON	OFF
78	OFF	ON	ON	ON	OFF	OFF	ON	OFF
79	ON	ON	ON	ON	OFF	OFF	ON	OFF
80	OFF	OFF	OFF	OFF	ON	OFF	ON	OFF
81	ON	OFF	OFF	OFF	ON	OFF	ON	OFF
82	OFF	ON	OFF	OFF	ON	OFF	ON	OFF
83	ON	ON	OFF	OFF	ON	OFF	ON	OFF
84	OFF	OFF	ON	OFF	ON	OFF	ON	OFF

# installation & connection

---

ID	SW1-#1	SW1-#2	SW1-#3	SW1-#4	SW1-#5	SW1-#6	SW1-#7	SW1-#8
85	ON	OFF	ON	OFF	ON	OFF	ON	OFF
86	OFF	ON	ON	OFF	ON	OFF	ON	OFF
87	ON	ON	ON	OFF	ON	OFF	ON	OFF
88	OFF	OFF	OFF	ON	ON	OFF	ON	OFF
89	ON	OFF	OFF	ON	ON	OFF	ON	OFF
90	OFF	ON	OFF	ON	ON	OFF	ON	OFF
91	ON	ON	OFF	ON	ON	OFF	ON	OFF
92	OFF	OFF	ON	ON	ON	OFF	ON	OFF
93	ON	OFF	ON	ON	ON	OFF	ON	OFF
94	OFF	ON	ON	ON	ON	OFF	ON	OFF
95	ON	ON	ON	ON	ON	OFF	ON	OFF
96	OFF	OFF	OFF	OFF	OFF	ON	ON	OFF
97	ON	OFF	OFF	OFF	OFF	ON	ON	OFF
98	OFF	ON	OFF	OFF	OFF	ON	ON	OFF
99	ON	ON	OFF	OFF	OFF	ON	ON	OFF
100	OFF	OFF	ON	OFF	OFF	ON	ON	OFF
101	ON	OFF	ON	OFF	OFF	ON	ON	OFF
102	OFF	ON	ON	OFF	OFF	ON	ON	OFF
103	ON	ON	ON	OFF	OFF	ON	ON	OFF
104	OFF	OFF	OFF	ON	OFF	ON	ON	OFF
105	ON	OFF	OFF	ON	OFF	ON	ON	OFF
106	OFF	ON	OFF	ON	OFF	ON	ON	OFF
107	ON	ON	OFF	ON	OFF	ON	ON	OFF
108	OFF	OFF	ON	ON	OFF	ON	ON	OFF
109	ON	OFF	ON	ON	OFF	ON	ON	OFF
110	OFF	ON	ON	ON	OFF	ON	ON	OFF
111	ON	ON	ON	ON	OFF	ON	ON	OFF
112	OFF	OFF	OFF	OFF	ON	ON	ON	OFF
113	ON	OFF	OFF	OFF	ON	ON	ON	OFF
114	OFF	ON	OFF	OFF	ON	ON	ON	OFF
115	ON	ON	OFF	OFF	ON	ON	ON	OFF
116	OFF	OFF	ON	OFF	ON	ON	ON	OFF
117	ON	OFF	ON	OFF	ON	ON	ON	OFF
118	OFF	ON	ON	OFF	ON	ON	ON	OFF
119	ON	ON	ON	OFF	ON	ON	ON	OFF
120	OFF	OFF	OFF	ON	ON	ON	ON	OFF
121	ON	OFF	OFF	ON	ON	ON	ON	OFF
122	OFF	ON	OFF	ON	ON	ON	ON	OFF
123	ON	ON	OFF	ON	ON	ON	ON	OFF
124	OFF	OFF	ON	ON	ON	ON	ON	OFF
125	ON	OFF	ON	ON	ON	ON	ON	OFF
126	OFF	ON	ON	ON	ON	ON	ON	OFF
127	ON	ON	ON	ON	ON	ON	ON	OFF



ID	SW1-#1	SW1-#2	SW1-#3	SW1-#4	SW1-#5	SW1-#6	SW1-#7	SW1-#8
128	OFF	OFF	OFF	OFF	OFF	OFF	OFF	ON
129	ON	OFF	OFF	OFF	OFF	OFF	OFF	ON
130	OFF	ON	OFF	OFF	OFF	OFF	OFF	ON
131	ON	ON	OFF	OFF	OFF	OFF	OFF	ON
132	OFF	OFF	ON	OFF	OFF	OFF	OFF	ON
133	ON	OFF	ON	OFF	OFF	OFF	OFF	ON
134	OFF	ON	ON	OFF	OFF	OFF	OFF	ON
135	ON	ON	ON	OFF	OFF	OFF	OFF	ON
136	OFF	OFF	OFF	ON	OFF	OFF	OFF	ON
137	ON	OFF	OFF	ON	OFF	OFF	OFF	ON
138	OFF	ON	OFF	ON	OFF	OFF	OFF	ON
139	ON	ON	OFF	ON	OFF	OFF	OFF	ON
140	OFF	OFF	ON	ON	OFF	OFF	OFF	ON
141	ON	OFF	ON	ON	OFF	OFF	OFF	ON
142	OFF	ON	ON	ON	OFF	OFF	OFF	ON
143	ON	ON	ON	ON	OFF	OFF	OFF	ON
144	OFF	OFF	OFF	OFF	ON	OFF	OFF	ON
145	ON	OFF	OFF	OFF	ON	OFF	OFF	ON
146	OFF	ON	OFF	OFF	ON	OFF	OFF	ON
147	ON	ON	OFF	OFF	ON	OFF	OFF	ON
148	OFF	OFF	ON	OFF	ON	OFF	OFF	ON
149	ON	OFF	ON	OFF	ON	OFF	OFF	ON
150	OFF	ON	ON	OFF	ON	OFF	OFF	ON
151	ON	ON	ON	OFF	ON	OFF	OFF	ON
152	OFF	OFF	OFF	ON	ON	OFF	OFF	ON
153	ON	OFF	OFF	ON	ON	OFF	OFF	ON
154	OFF	ON	OFF	ON	ON	OFF	OFF	ON
155	ON	ON	OFF	ON	ON	OFF	OFF	ON
156	OFF	OFF	ON	ON	ON	OFF	OFF	ON
157	ON	OFF	ON	ON	ON	OFF	OFF	ON
158	OFF	ON	ON	ON	ON	OFF	OFF	ON
159	ON	ON	ON	ON	ON	OFF	OFF	ON
160	OFF	OFF	OFF	OFF	OFF	ON	OFF	ON
161	ON	OFF	OFF	OFF	OFF	ON	OFF	ON
162	OFF	ON	OFF	OFF	OFF	ON	OFF	ON
163	ON	ON	OFF	OFF	OFF	ON	OFF	ON
164	OFF	OFF	ON	OFF	OFF	ON	OFF	ON
165	ON	OFF	ON	OFF	OFF	ON	OFF	ON
166	OFF	ON	ON	OFF	OFF	ON	OFF	ON
167	ON	ON	ON	OFF	OFF	ON	OFF	ON
168	OFF	OFF	OFF	ON	OFF	ON	OFF	ON
169	ON	OFF	OFF	ON	OFF	ON	OFF	ON
170	OFF	ON	OFF	ON	OFF	ON	OFF	ON

# installation & connection

---

ID	SW1-#1	SW1-#2	SW1-#3	SW1-#4	SW1-#5	SW1-#6	SW1-#7	SW1-#8
171	ON	ON	OFF	ON	OFF	ON	OFF	ON
172	OFF	OFF	ON	ON	OFF	ON	OFF	ON
173	ON	OFF	ON	ON	OFF	ON	OFF	ON
174	OFF	ON	ON	ON	OFF	ON	OFF	ON
175	ON	ON	ON	ON	OFF	ON	OFF	ON
176	OFF	OFF	OFF	OFF	ON	ON	OFF	ON
177	ON	OFF	OFF	OFF	ON	ON	OFF	ON
178	OFF	ON	OFF	OFF	ON	ON	OFF	ON
179	ON	ON	OFF	OFF	ON	ON	OFF	ON
180	OFF	OFF	ON	OFF	ON	ON	OFF	ON
181	ON	OFF	ON	OFF	ON	ON	OFF	ON
182	OFF	ON	ON	OFF	ON	ON	OFF	ON
183	ON	ON	ON	OFF	ON	ON	OFF	ON
184	OFF	OFF	OFF	ON	ON	ON	OFF	ON
185	ON	OFF	OFF	ON	ON	ON	OFF	ON
186	OFF	ON	OFF	ON	ON	ON	OFF	ON
187	ON	ON	OFF	ON	ON	ON	OFF	ON
188	OFF	OFF	ON	ON	ON	ON	OFF	ON
189	ON	OFF	ON	ON	ON	ON	OFF	ON
190	OFF	ON	ON	ON	ON	ON	OFF	ON
191	ON	ON	ON	ON	ON	ON	OFF	ON
192	OFF	OFF	OFF	OFF	OFF	OFF	ON	ON
193	ON	OFF	OFF	OFF	OFF	OFF	ON	ON
194	OFF	ON	OFF	OFF	OFF	OFF	ON	ON
195	ON	ON	OFF	OFF	OFF	OFF	ON	ON
196	OFF	OFF	ON	OFF	OFF	OFF	ON	ON
197	ON	OFF	ON	OFF	OFF	OFF	ON	ON
198	OFF	ON	ON	OFF	OFF	OFF	ON	ON
199	ON	ON	ON	OFF	OFF	OFF	ON	ON
200	OFF	OFF	OFF	ON	OFF	OFF	ON	ON
201	ON	OFF	OFF	ON	OFF	OFF	ON	ON
202	OFF	ON	OFF	ON	OFF	OFF	ON	ON
203	ON	ON	OFF	ON	OFF	OFF	ON	ON
204	OFF	OFF	ON	ON	OFF	OFF	ON	ON
205	ON	OFF	ON	ON	OFF	OFF	ON	ON
206	OFF	ON	ON	ON	OFF	OFF	ON	ON
207	ON	ON	ON	ON	OFF	OFF	ON	ON
208	OFF	OFF	OFF	OFF	ON	OFF	ON	ON
209	ON	OFF	OFF	OFF	ON	OFF	ON	ON
210	OFF	ON	OFF	OFF	ON	OFF	ON	ON
211	ON	ON	OFF	OFF	ON	OFF	ON	ON
212	OFF	OFF	ON	OFF	ON	OFF	ON	ON
213	ON	OFF	ON	OFF	ON	OFF	ON	ON

ID	SW1-#1	SW1-#2	SW1-#3	SW1-#4	SW1-#5	SW1-#6	SW1-#7	SW1-#8
214	OFF	ON	ON	OFF	ON	OFF	ON	ON
215	ON	ON	ON	OFF	ON	OFF	ON	ON
216	OFF	OFF	OFF	ON	ON	OFF	ON	ON
217	ON	OFF	OFF	ON	ON	OFF	ON	ON
218	OFF	ON	OFF	ON	ON	OFF	ON	ON
219	ON	ON	OFF	ON	ON	OFF	ON	ON
220	OFF	OFF	ON	ON	ON	OFF	ON	ON
221	ON	OFF	ON	ON	ON	OFF	ON	ON
222	OFF	ON	ON	ON	ON	OFF	ON	ON
223	ON	ON	ON	ON	ON	OFF	ON	ON
224	OFF	OFF	OFF	OFF	OFF	ON	ON	ON
225	ON	OFF	OFF	OFF	OFF	ON	ON	ON
226	OFF	ON	OFF	OFF	OFF	ON	ON	ON
227	ON	ON	OFF	OFF	OFF	ON	ON	ON
228	OFF	OFF	ON	OFF	OFF	ON	ON	ON
229	ON	OFF	ON	OFF	OFF	ON	ON	ON
230	OFF	ON	ON	OFF	OFF	ON	ON	ON
231	ON	ON	ON	OFF	OFF	ON	ON	ON
232	OFF	OFF	OFF	ON	OFF	ON	ON	ON
233	ON	OFF	OFF	ON	OFF	ON	ON	ON
234	OFF	ON	OFF	ON	OFF	ON	ON	ON
235	ON	ON	OFF	ON	OFF	ON	ON	ON
236	OFF	OFF	ON	ON	OFF	ON	ON	ON
237	ON	OFF	ON	ON	OFF	ON	ON	ON
238	OFF	ON	ON	ON	OFF	ON	ON	ON
239	ON	ON	ON	ON	OFF	ON	ON	ON
240	OFF	OFF	OFF	OFF	ON	ON	ON	ON
241	ON	OFF	OFF	OFF	ON	ON	ON	ON
242	OFF	ON	OFF	OFF	ON	ON	ON	ON
243	ON	ON	OFF	OFF	ON	ON	ON	ON
244	OFF	OFF	ON	OFF	ON	ON	ON	ON
245	ON	OFF	ON	OFF	ON	ON	ON	ON
246	OFF	ON	ON	OFF	ON	ON	ON	ON
247	ON	ON	ON	OFF	ON	ON	ON	ON
248	OFF	OFF	OFF	ON	ON	ON	ON	ON
249	ON	OFF	OFF	ON	ON	ON	ON	ON
250	OFF	ON	OFF	ON	ON	ON	ON	ON
251	ON	ON	OFF	ON	ON	ON	ON	ON
252	OFF	OFF	ON	ON	ON	ON	ON	ON
253	ON	OFF	ON	ON	ON	ON	ON	ON
254	OFF	ON	ON	ON	ON	ON	ON	ON
255	ON	ON	ON	ON	ON	ON	ON	ON

# installation & connection

## INSTALLATION (SNP-3120)

### On-ceiling installation

1. Drill a hole of 60mm diameter on the ceiling and run the wires down through it.
2. Install the Mount Bracket onto the hold and fix it using 4 screws.

- !** Do not connect the camera to a power outlet until the installation is complete. Supplying power in the middle of the installation may cause fire or damage the product.

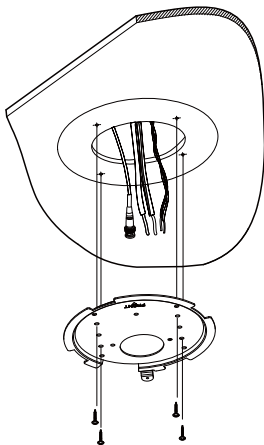

3. Connect each camera cable to the proper terminals on the bottom of the camera. For more detailed instructions, please refer to Page 16: "Camera Wiring Interface Board".
4. DIP switches for communication and ID setup are located on the bottom of the camera. For more instructions, please refer to Page 22.

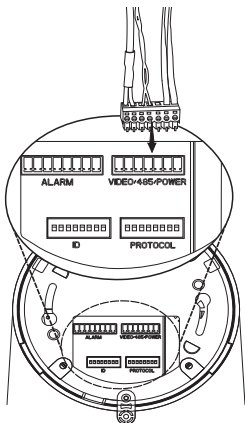

5. Align the **“Align The Arrow”** triangular edge of the camera to the marking (shown as **“A”** in the diagram) on the left of the **“FRONT”** side of the Mount Bracket.
6. After inserting the camera into the Mount Bracket, turn the camera module clockwise about 25°.

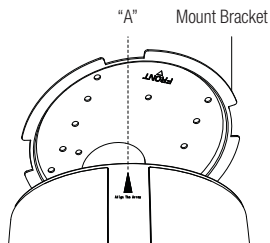

7. Match the screw holes in the camera and mount bracket, and then fasten with the screw.

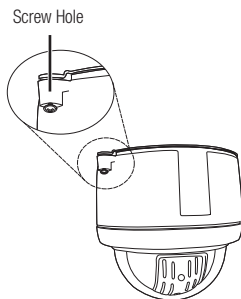

# installation & connection

---

## Flush Mount Type Installation Example

1. Attach the template, and then drill a hole according to the 143 mm diameter hole marked on the template. Drop down the camera cables through the hole. Drill another small hole for a screw to secure the camera.

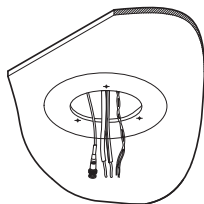

2. Rotate the dome cover counterclockwise to detach it from the camera.

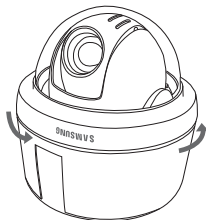

3. Remove the 3 screws, and then detach the mount housing from the camera.

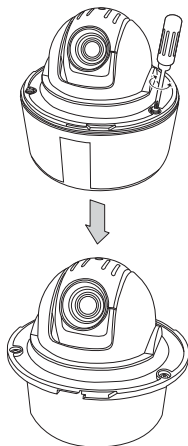

4. Connect each camera cable to the proper terminals on the bottom of the camera (Refer to Page 16: “**Camera Wiring Interface Board**”). Configure the DIP switches on the bottom of the camera for communication and ID (Refer to pages 19~21).

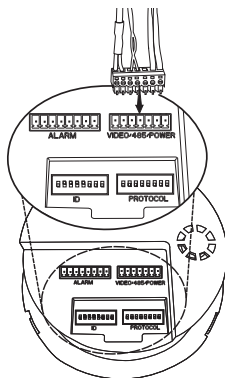

5. Install Camera Fit the camera to the hole on the ceiling, and then secure the camera using 3 Product-enclosed Fixture Screws (M4x20).

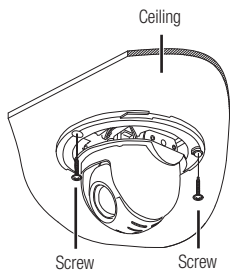

6. Assemble Dome Cover Insert the grooves on the dome cover into ones on the camera, and then turn clockwise to fasten.

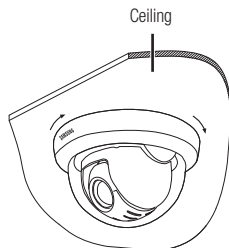

# installation & connection

## INSTALLING WITH ACCESSORIES (SOLD SEPARATELY)

1. Turn the Dome Cover counter-clockwise and separate from the camera.

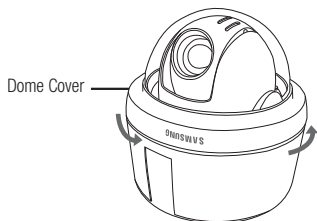

2. Remove 3 screws and separate the Mount Housing from the camera.

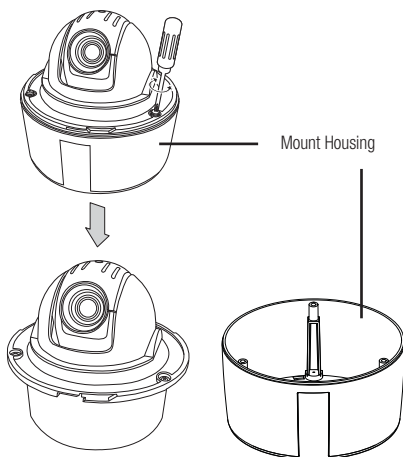



3. Fix the Mount Housing onto the Hanging Mount (SBP-300HM) with 4 screws (M4xL16).

- !** Note that the recommended torque for the screw fastening is less than 3 kgf, to prevent deformation of the mount housing.

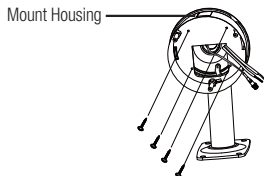
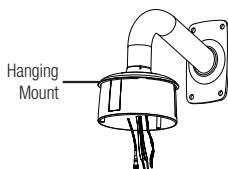

4. Connect wires to the Terminal Block and attach it to the bottom side of the camera.  
(Refer to the “**Camera Wiring Interface Board**” at page 16.)  
Set the communication protocol and ID DIP switches on the bottom of the camera unit. (Refer to pages 19~21.)

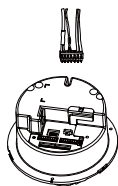

5. Fix the camera to the Mount Housing by using 3 screws removed in the step 2.



6. Attach the Dome Cover and turn it clockwise to fix.

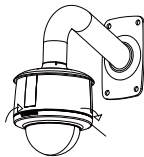

# installation & connection

## INSTALLATION (SNP-3120V)

### Ceiling Mount

1. Use the provided L-shaped wrench to remove the surface mount by loosening 4 screws counter clockwise.

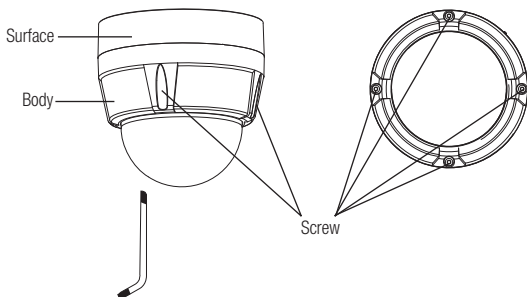

2. Drill holes (5 mm in diameter and at least 35 mm in depth for each) for the screws (x4) to be inserted in the bottom of the surface mount, and insert the provided plastic anchor (HUD5) to the end.

Insert the cables into the cable hole, and fix the SCREW-TAPPING (TH M4xL30) to the plastic anchor that was inserted in the hole for fixing the surface mount. (x4)

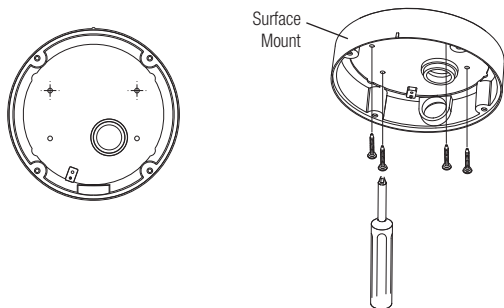

3. Connect the safety wire (attached to the camera) to the surface mount as shown. Then, arrange the cables.
- For more information about the wiring, refer to "**Camera Wiring Interface Board**". (Page 16)

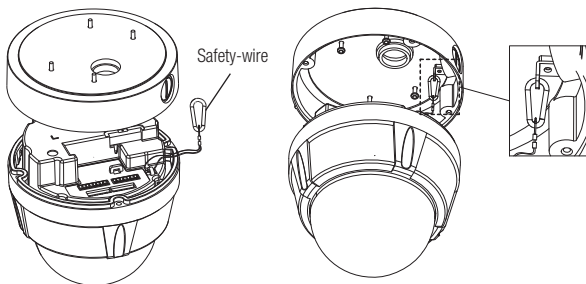

4. Arrange the cables inside the surface mount so that they should not be entangled or stuck in, and align the guide rib of the camera with that of the surface mount. Use the L-shaped wrench to tighten the screws (x4) so that the camera is secured to the mount. To ensure waterproofness, take caution lest that the outer gasket should get loose or be stuck in.

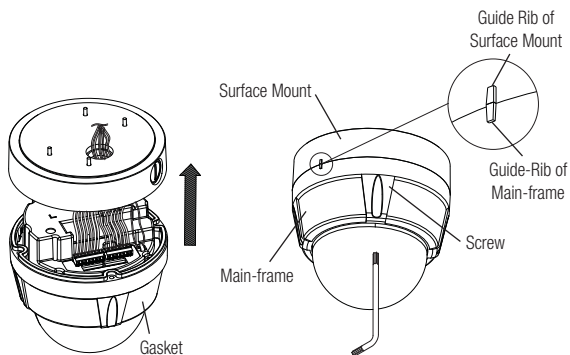

# installation & connection

---

## Mount onto the optimal adaptor

1. Follow step 1 in **"Ceiling Mount"** above and remove the surface mount.
2. Insert the cables into the cable hole on the surface mount and fix them to SBP-300HM (HANGING MOUNT) using SCREW-MACHINE (BH, M4xL10, x4).

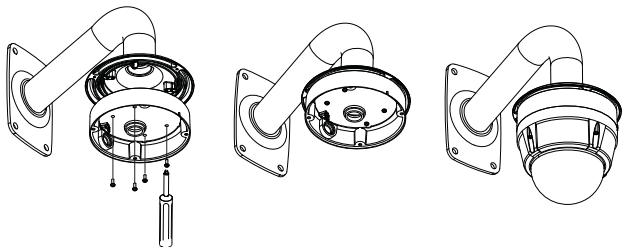

3. Repeat step 3 through step 4 in **"Ceiling Mount"** above to complete the installation.

## INSTALLATION (SNP-3120VH)

1. Use the provided L-shaped wrench to loosen 4 screws counter clockwise, which will help removing the housing.

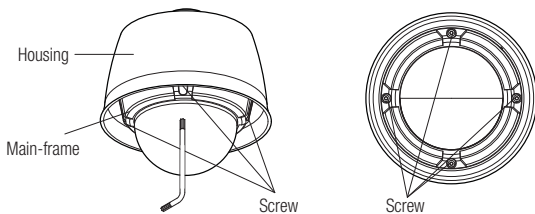

2. Fix the housing to the NP 1.5" tapped pipe, wall mount (SBP-300WM) or ceiling mount (SBP-300CM) by turning it clockwise. For waterproofness and lock between the two component parts, use the Teflon tape to wrap them around.

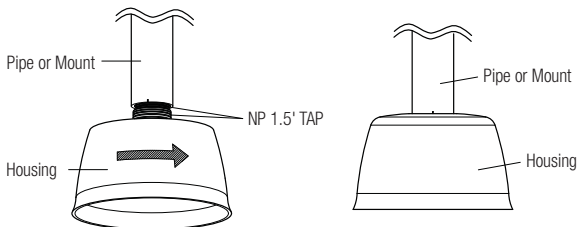

# installation & connection

- Secure the safety wire (attached to the product) to the housing as shown.
  - For details about the cable connection, refer to the **"Camera Wiring Interface Board"** section in this manual.

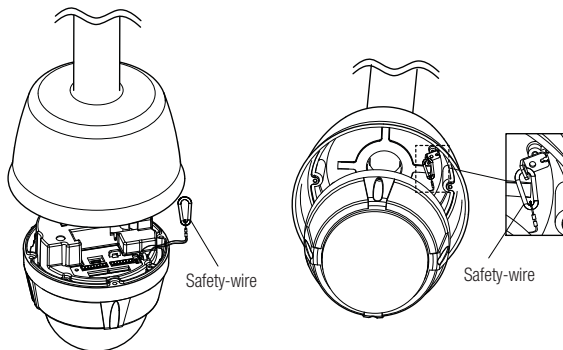

- Arrange the cables inside the housing lest they be damaged or stuck in, and use the L-shaped wrench to tighten 4 screws to the housing. To ensure waterproofness, this step needs your special care. Otherwise, the gasket on the outer side of the product may be loose or just stuck in.

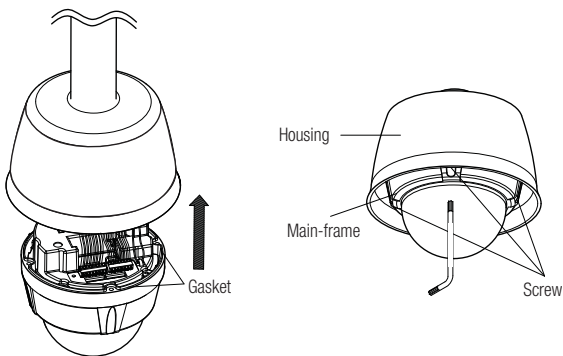

## Optional Accessories for Installation

For your easier installation, you can purchase appropriate optional accessories available.

### 1. When installing the camera on a wall

- SNP-3120, SNP-3120V :  
Wall mount (SBP-300WM) + Hanging mount (SBP-300HM)



- SNP-3120VH :  
Wall mount (SBP-300WM)



### 2. When installing the camera on a ceiling

- SNP-3120, SNP-3120V :  
Ceiling mount (SBP-300CM) + Hanging mount (SBP-300HM)

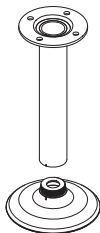

- SNP-3120VH :  
Ceiling mount (SBP-300CM)

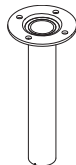

# installation & connection

---

3. When installing the Wall Mount (SBP-300WM) on a pole bigger than 80mm in diameter :  
Pole Mount (SBP-300PM)

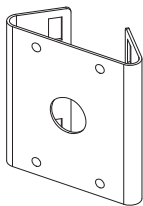

4. When installing the Wall Mount (SBP-300WM) on a cornered wall :  
Corner Mount (SBP-300KM)

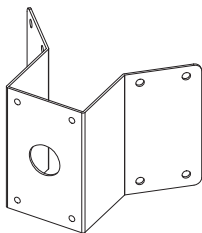

5. When installing SNP-3120VH on a rooftop of a building :  
Parapet Mount (SBP-300LM)

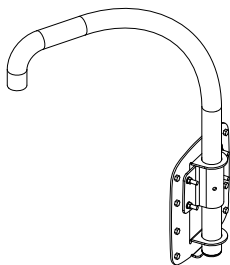



## INSERTING/REMOVING AN SD MEMORY CARD

### Inserting an SD Memory Card

Push the SD memory card in the direction of the arrow shown in the diagram.

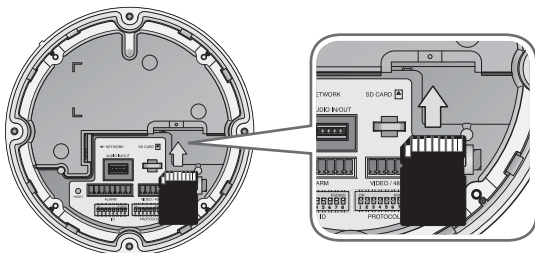

- ! Do not insert the SD memory card while it's upside down by force. Otherwise, it may damage the SD memory card.

### Removing an SD Memory Card

Gently press down on the exposed end of the memory card as shown in the diagram to eject the memory card from the slot.

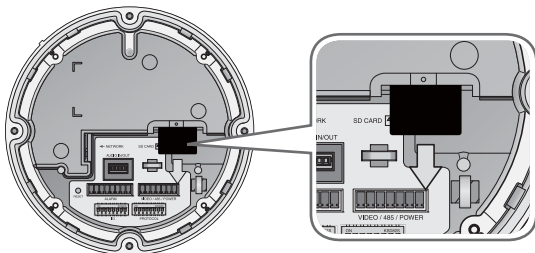

- ! Pressing too hard on the SD memory card can cause the card to shoot out uncontrollably from the slot when released.
- To remove the SD memory card, set **<Record>** to **<Off>** from **<SD record>** and press **[Apply (  )]**. (page 94)
- If you have saved data in the SD memory card, removing the SD memory card prior to setting record to OFF will cause damage to the data stored in the card.

## MEMORY CARD INFORMATION (NOT INCLUDED)

---

### What is a memory card?

The memory card is an external data storage device that has been developed to offer an entirely new way to record and share video, audio, and text data using digital devices.

### Selecting a memory card that's suitable for you

Your camera supports SDHC memory cards.

You may, however, experience compatibility issues depending on the model and make of the memory card.

For your camera, we recommend you use a memory card from the following manufacturers:

SDHC/SD Memory Card : Sandisk, Transcend, Kingston

Playback performance can be affected depending on the speed of memory card, so use the high-speed memory card.

### Memory Card Use

SD and SDHC memory cards feature a switch that disables writing data on to the media.

Having this switch to the Lock position will prevent accidental deletion of data stored in the memory card but at the same time will also prevent you from writing data on to the media.

### ❖ Memory Card Components

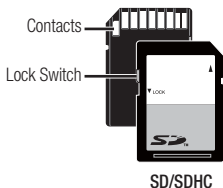

## CONNECTING WITH OTHER DEVICE

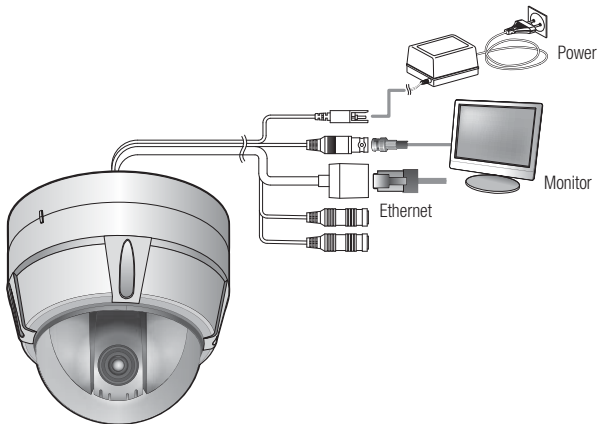

### Connecting to the monitor

Connect the video out port of the camera to the video input port of the monitor.



- In the initial installation of the camera, you can connect the camera to the monitor for checking the connection status.
- Connect the monitor test cable to the output port of the monitor.

### Ethernet Connection

Connect the Ethernet cable to the local network or to the Internet.

### Power Supply

Use the screwdriver to connect each line (+, -) of the power cable to the corresponding power port of the camera.



- You can also use a router featuring PoE (Power over Ethernet) to supply power to the camera.
- If using PoE, the heater will not operate at all. (SNP-3120V/VH)  
Use an adaptor if the installation site requires heater operations. Adaptor is sold separately.  
For the power specifications, refer to the "**Appendix**". (page 108)

# installation & connection

## Connecting to Audio Input/Output

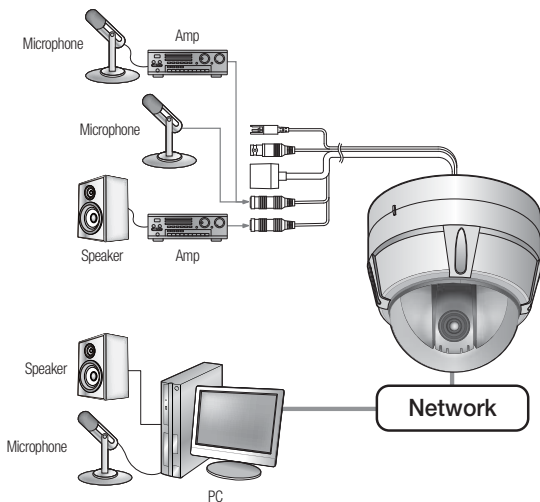

1. Connect the AUDIO IN port of the camera with the microphone directly or LINE OUT port of the amplifier that the microphone is connected to.
2. Connect the AUDIO OUT port of the camera with the LINE IN port of the speaker.
3. Check the specifications for audio input.

- **Audio Codec**  
G.711 PCM.  $\mu$ -law 64kbps 8kHz sampling
- **Full duplex Audio**
- **Audio in**  
Used for mono signal line input (Max.2.4 Vpp)
- **Audio out**  
Used for mono signal line output (Max.2.4 Vpp)
- **Line out impedance**  
600 $\Omega$

## Alarm I/O Wiring Diagram

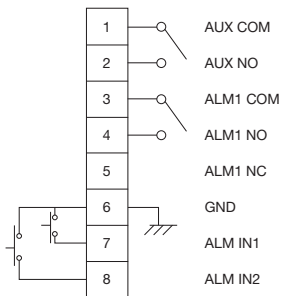

## Connecting to the I/O port box

Connect the Alarm I/O signal to the corresponding port of the rear port box.

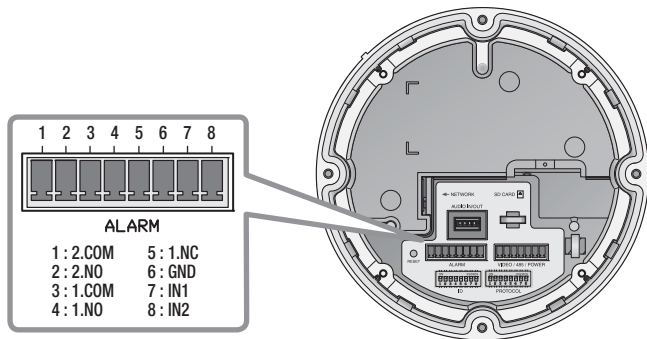

- For further details on each terminal refer to "Camera Wiring Interface Board" (page 16)

# network connection and setup

You can set up the network settings according to your network configurations.

## CONNECTING THE CAMERA DIRECTLY TO LOCAL AREA NETWORKING

### Connecting to the camera from a local PC in the LAN

1. Launch an Internet browser on the local PC.
2. Enter the IP address of the camera in the address bar of the browser.

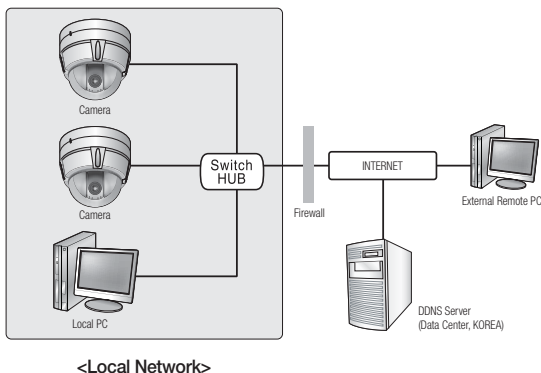

- A remote PC in an external Internet out of the LAN network may not be able to connect to the camera installed in the intranet if the port-forwarding is not properly set or a firewall is set. In this case, to resolve the problem, contact your network administrator.
- By factory default, the IP address will be assigned from the DHCP server automatically. If there is no DHCP server available, the IP address will be set to 192.168.1.100. To change the IP address, use the IP Installer. For further details on IP Installer use, refer to "Static IP Setup". (Page 51)

## CONNECTING THE CAMERA DIRECTLY TO A DHCP BASED DSL/CABLE MODEM

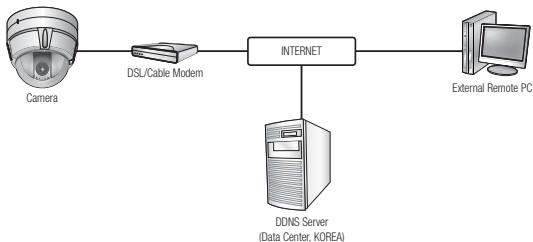

1. Use the cross LAN cable to connect the network cable directly to your PC.
2. Run the IP Installer and change the IP address of the camera so that you can use the web browser on your desktop to connect to the Internet.
3. Use the Internet browser to connect to the camera.
4. Move to [**Setup**] page.
5. Move to [**Network**] – [**DDNS**] and configure the DDNS settings.
6. Move to [**Network**] – [**Interface**], and set the network type to [**DHCP**].
7. Connect the camera, which was removed from your PC, directly to the modem.
8. Restart the camera.



- For registering the DDNS settings, refer to "**Registering with DDNS**". (page 90)
- For configuring the DDNS settings, refer to "**DDNS**". (page 89)
- For setting the network type, refer to "**Interface**". (page 88)

# network connection and setup

---

## CONNECTING THE CAMERA DIRECTLY TO A PPPoE MODEM

---

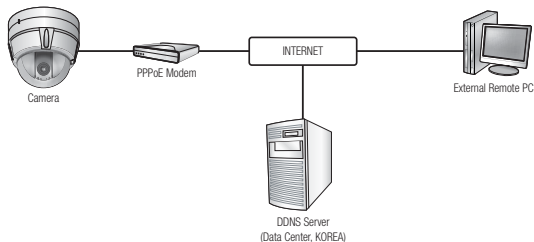

1. Use the cross LAN cable to connect the network cable directly to your PC.
2. Run the IP Installer and change the IP address of the camera so that you can use the web browser on your desktop to connect to the Internet.
3. Use the Internet browser to connect to the camera.
4. Move to [**Setup**] page.
5. Move to [**Network**] – [**DDNS**] and configure the DDNS settings.
6. Move to [**Network**] – [**Interface**], and set the network type to [**PPPoE**].
7. Connect the camera, which was removed from your PC, directly to the modem.
8. Restart the camera.



- For registering the DDNS settings, refer to "**Registering with DDNS**". (page 90)
- For configuring the DDNS settings, refer to "**DDNS**". (page 89)
- For setting the network type, refer to "**Interface**". (page 88)



## CONNECTING THE CAMERA TO AN IP ROUTER WITH THE PPPOE/CABLE MODEM

This is for a small network environment such as homes, SOHO and ordinary shops.

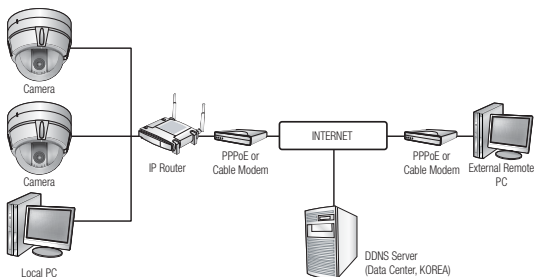

### Configuring the network settings of the local PC connected to an IP router

Configuring the network settings of the local PC connected to an IP router, follow the instructions below.

- Select : <Network Neighborhood> → <Properties> → <Local Area Connection> → <Properties> → <General> → <Internet Protocol (TCP/IP)> → <Properties> → <Obtain an IP address automatically> or <Use the following IP address>.
- Follow the instructions below if you select <Use the following IP address>:
  - ex1) If the address (LAN IP) of the IP router is 192.168.1.1  
 IP address : 192.168.1.100  
 Subnet Mask : 255.255.255.0  
 Default Gateway : 192.168.1.1
  - ex2) If the address (LAN IP) of the IP router is 192.168.0.1  
 IP address : 192.168.0.100  
 Subnet Mask : 255.255.255.0  
 Default Gateway : 192.168.0.1
  - ex3) If the address (LAN IP) of the IP router is 192.168.xxx.1  
 IP address : 192.168.xxx.100  
 Subnet Mask : 255.255.255.0  
 Default Gateway : 192.168.xxx.1



- For the address of the IP router, refer to the product's documentation.
- Refer to the "**Port Range Forward (Port Mapping) Setup**" section of the IP Router's documentation. (Page 55)

# network connection and setup

## BUTTONS USED IN IP INSTALLER

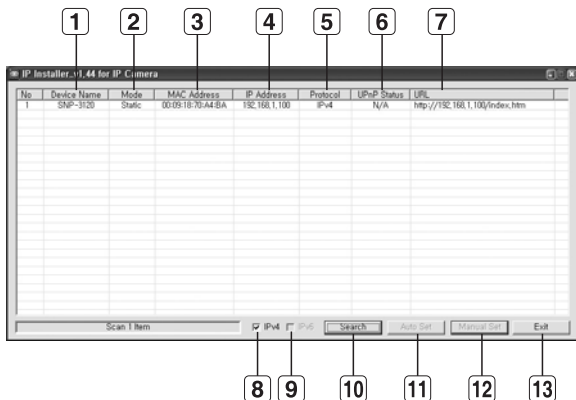

Item	Description
<b>1</b> Device Name	Model name of the connected camera. Click the column to sort the list by model name. However, search will be stopped if clicked during the search.
<b>2</b> Mode	Displays either <Static> or <Dynamic> for the current network connection status.
<b>3</b> MAC(Ethernet) Address	Ethernet address for the connected camera. Click the column to sort the list by Ethernet address. However, search will be stopped if clicked during the search.
<b>4</b> IP Address	IP address. Click the column to sort the list by IP address. However, search will be stopped if clicked during the search. The factory default is "192.168.1.100".
<b>5</b> Protocol	Network setting for the camera. The factory default is "IPv4". Cameras with the IPv6 setting will be displayed "IPv6".
<b>6</b> UPnP Status	This function is not currently implemented.

Item	Description
<b>7</b> URL	DDNS URL address enabling access from the external Internet. However, this will be replaced with the <IP Address> of the camera if DDNS registration has failed.
<b>8</b> IPv4	Scans for cameras with the IPv4 setting.
<b>9</b> IPv6	Scans for cameras with the IPv6 setting.
<b>10</b> Search	Scans for cameras that are currently connected to the network. However, this button will be grayed out if neither IPv4 nor IPv6 is checked.
<b>11</b> Auto Set	The IP Installer automatically configures the network settings.
<b>12</b> Manual Set	You should configure the network settings manually.
<b>13</b> Exit	Exits the IP Installer program.



- For the IP installer, use only the installer version provided in the installation DVD or use the latest one if available. You can download the latest version from the product website.

## STATIC IP SETUP

### Manual Network Setup

Run <IP Installer\_vX.XX.exe> to display the camera search list.

At the initial startup, both [Auto Set] and [Manual Set] will be grayed out.



- For cameras found with the IPv6 setting, these buttons will be grayed out as the cameras do not support this function.

- Select a camera in the search list.  
Find the MAC (Ethernet) address labeled on the rear of the camera.  
Both the [Auto Set] and [Manual Set] buttons will be activated.
- Click [Manual Set].  
The Manual Setting dialog appears.  
The default values of <IP Address>, <Subnet Mask>, <Gateway>, <HTTP Port> and <VNP Port> of the camera will be displayed.

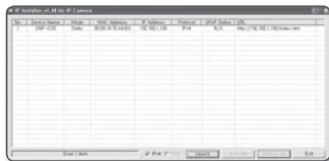

# network connection and setup

3. In the <Address> pane, provide the necessary information.

- MAC (Ethernet) Address : The MAC (Ethernet) address of the applicable camera will be set automatically so you don't need to input it manually.



- You can configure the static IP settings only if the DHCP checkbox is unchecked.

Address	<input type="checkbox"/> DHCP	Port	HTTP Port	80
MAC Address	08:00:30:00:00:00	VNP Port	4520	
IP Address	192 - 168 - 1 - 100			
Subnet Mask	255 - 255 - 255 - 0			
Gateway	192 - 168 - 1 - 1			
Password	<input type="text"/>			
OK		Cancel		

## If using an IP router

- IP Address : Enter an address falling in the IP range provided by the IP router.  
ex) 192.168.1.2~254,  
192.168.0.2~254,  
192.168.XXX.2~254
- Subnet Mask : The <Subnet Mask> of the IP router will be the <Subnet Mask> of the camera.
- Gateway : The <Local IP Address> of the IP router will be the <Gateway> of the camera.

Internet Setup	Automatic Configuration - DHCP <input checked="" type="checkbox"/>
Router Name	Router_1
Host Name	
Domain Name	
MTU	Manual <input type="checkbox"/>
Size	1492
Local IP Address	192 - 168 - 1 - 1
Subnet Mask	255 - 255 - 255 - 0



- The settings may differ depending on the connected IP router model. For more information, refer to the user manual of the applicable router.
- Refer to the "**Port Range Forward (Port Mapping) Setup**" section of the IP Router's documentation. (Page 55)

## If not using an IP router

For setting <IP Address>, <Subnet Mask>, and <Gateway>, contact your network administrator.

4. In the <Port> pane, provide necessary information.

- HTTP Port : Used to access the camera using the Internet browser, defaulted to 80. Use the spin button to change the HTTP Port value.
- VNP Port : Used to control the video signal transfer, defaulted to 4520.

Address	<input type="checkbox"/> DHCP	Port	HTTP Port	80
MAC Address	08:00:30:00:00:00	VNP Port	4520	
IP Address	192 - 168 - 1 - 100			
Subnet Mask	255 - 255 - 255 - 0			
Gateway	192 - 168 - 1 - 1			
Password	<input type="text"/>			
OK		Cancel		

5. Enter the password.

- This is the login password for the "admin" user who accesses the camera. The default password is "4321".



- The default password can be exposed to a hacking thread so it is recommended to change the password after installing the product.  
Note that the security and other related issues caused by the unchanged password shall be responsible for the user.

6. Click [OK].

Manual network setup will be completed.

7. When the manual setup including IP is completed, the camera will restart.

**If the IP router has more than one camera connected**

Configure the IP related settings and the Port related settings distinctly with each other.

Category		Camera #1	Camera #2
IP related settings	IP Address	192.168.1.100	192.168.1.101
	Subnet Mask	255.255.255.0	255.255.255.0
	Gateway	192.168.1.1	192.168.1.1
Port related settings	HTTP Port	8080	8081
	VNP Port	4520	4521



- If the <HTTP Port> is set other than 80, you must provide the <Port> number in the address bar of the Internet browser before you can access the camera.  
ex) http://IP address : HTTP Port  
http://192.168.1.100:8080

**Auto Network Setup**

Run <IP Installer\_vX.XX.exe> to display the camera search list.

At the initial startup, both [Auto Set] and [Manual Set] will be grayed out.



- For cameras found with the IPv6 setting, these buttons will be grayed out as the cameras do not support this function.

1. Select a camera in the search list.  
Find the MAC (Ethernet) address labeled on the rear of the camera.  
Both the [Auto Set] and [Manual Set] buttons will be activated.
2. Click [Auto Set].  
The Auto Setting dialog appears.  
The <IP Address>, <Subnet Mask>, and <Gateway> will be set automatically.

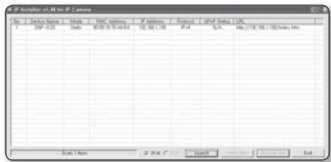

# network connection and setup

### 3. Enter the password.

This is the login password for the “admin” user who accesses the camera. The default password is “4321”.

- The default password can be exposed to a hacking thread so it is recommended to change the password after installing the product.

Note that the security and other related issues caused by the unchanged password shall be responsible for the user.

### 4. Click [OK].

Auto network setup will be completed.

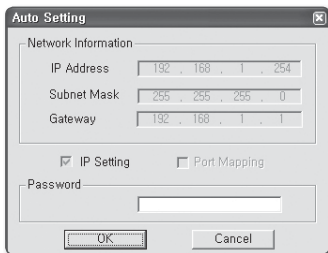

## DYNAMIC IP SETUP

### Dynamic IP Environment Setup

- Example of the Dynamic IP environment
  - If an IP router, with cameras connected, is assigned an IP address by the DHCP server
  - If connecting the camera directly to modem using the DHCP protocols
  - If IPs are assigned by the internal DHCP server via the LAN

### Checking the Dynamic IP

1. Run the IP Installer on the user's local machine to display cameras allocated with <Dynamic IP> addresses in the list.
2. Select a camera in the list, and click [Manual Set] to check the <Dynamic IP> of the camera.  
If you uncheck <DHCP>, you can change IP or <Port> to <Static>.

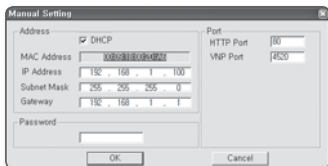
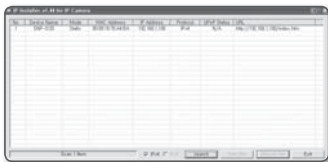

## PORT RANGE FORWARD (PORT MAPPING) SETUP

If you have installed an IP router with a camera connected, you must set the port range forwarding on the IP router so that a remote PC can access the camera in it.

### Manual Port Range Forwarding

1. From the Setup menu of the IP router, select **<Applications & Gaming>** - **<Port Range Forward>**.

For setting the port range forward for a third-party IP router, refer to the user guide of that IP router.

2. Select **<TCP>** and **<UDP Port>** for each connected camera to the IP router.

Each port number for the IP router should match that specified in **<Network>** - **<Port>** from the camera's Setup menu.

3. When done, click **[Save Settings]**.  
Your settings will be saved.

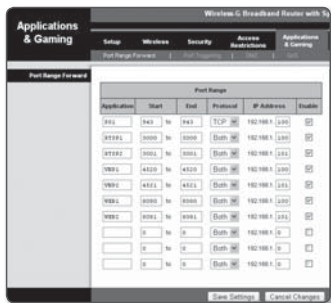

-  ■ Above sample instructions are based on the CISCO's IP Router (Model: LINKSYS).
- The settings may differ depending on the connected IP router model.  
For more information, refer to the user manual of the applicable router.

# network connection and setup

## Setting up Port Range Forward for several network cameras

When several network camera connect to one IP router device, you should forward the TCP 943 port of the router to the TCP 943 port of a connected camera.

**!** If you don't set properly the TCP 943 port of the router, you cannot get any video stream from the web page of the camera.

- TCP 943 port is a port for the Silverlight policy server of a camera.

When Camera1 and Camera2 are connected to a router :

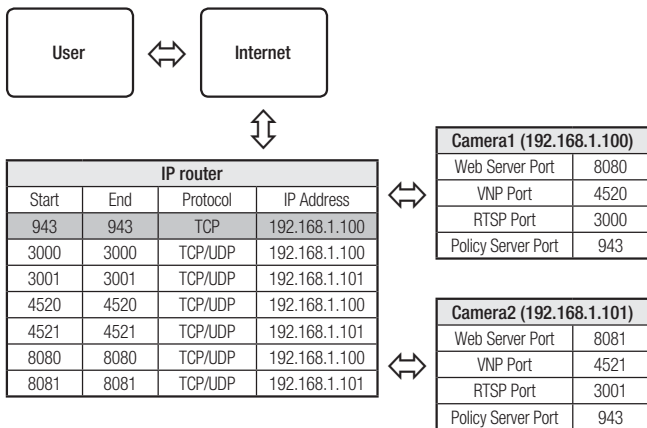

- You can set a rule of Port Forwarding on the IP router device through its configuration web page.
- You cannot change the Silverlight policy server port of a camera.
- You can change the ports of the camera except the policy server port through its configuration web pages.



## CONNECTING TO THE CAMERA FROM A SHARED LOCAL PC

1. Run the IP Installer.  
It will scan for connected cameras and display a list of them.
2. Double-click a camera to access.  
The Internet browser starts and connects to the camera.

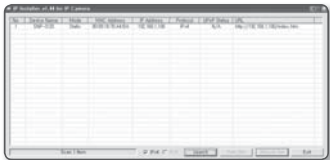

- Access to the camera can also be gained by typing the camera's IP address in the address bar of the Internet browser.

## CONNECTING TO THE CAMERA FROM A REMOTE PC VIA THE INTERNET

Since using the IP Installer on a remote computer that is not in the IP Router's network cluster is not allowed, users can access cameras within an IP Router's network by using the camera's DDNS URL.

1. Before you can access a camera in the IP router network, you should have set the port range forward for the IP router.
2. From the remote PC, launch the Internet browser and type the DDNS URL address of the camera, or the IP address of the IP router in the address bar.  
ex) [http://www.samsungipolis.com/\[Product ID\]](http://www.samsungipolis.com/[Product ID])

## CONNECTING TO THE CAMERA

---

### Normally, you would

1. Launch the Internet browser.
2. Type the IP address of the camera in the address bar.
  - ex) • IP address (IPv4) : 192.168.1.100  
→ http://192.168.1.100
  - the Login dialog should appear.
  - IP address (IPv6) : 2001:230:abcd:ffff:0000:0000:ffff:1111  
→ http://[2001:230:abcd:ffff:0000:0000:ffff:1111]

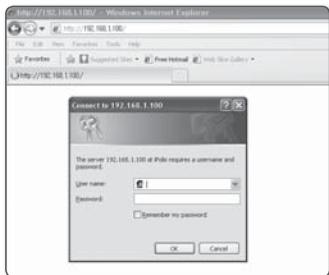

### If the HTTP port is other than 80

1. Launch the Internet browser.
2. Type the IP address and HTTP port number of the camera in the address bar.
  - ex) IP address : 192.168.1.100:HTTP Port number(8080)  
→ http://192.168.1.100:8080 - the Login dialog should appear.

### Using URL

1. Launch the Internet browser.
2. Type the DDNS URL of the camera in the address bar.
  - ex) URL address : http://www.samsungipolis.com/[Product ID]  
- the Login dialog should appear.

## To check the DDNS address

If the camera is connected directly to the DHCP cable modem, DSL modem, or PPPoE modem, the IP address of your network will be changed each time you try to connect to the ISP (Internet Service Provider) server.

If this is the case, you will not be informed of the IP address changed by DDNS.

Once you register a dynamic IP-based device with the DDNS server, you can easily check the changed IP when you try to access the device.



To add the IP address to the <DDNS> server, visit [www.samsungipolis.com](http://www.samsungipolis.com) and register your device, and set the DDNS option to <Samsung DDNS> before providing the host name for the DDNS server.

## LOGIN

The default user ID is “admin”, and the default password is “4321”.

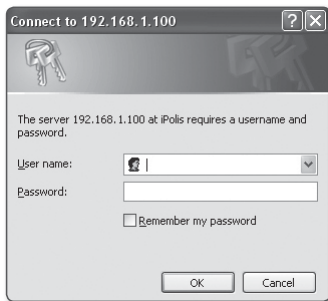
1. Enter “admin” in the <User Name> input box.
2. Enter “4321” in the <Password> input box.  
If the password is changed, enter the changed password instead.
3. Click [OK].  
If you have logged in successfully, you will the Live Viewer screen.



- 
  - For security purposes, ensure that you change the password in <System> - <User>.  
The administrator ID, “admin”, is fixed and can not be changed.
  - The default password can be exposed to a hacking thread so it is recommended to change the password after installing the product.  
Note that the security and other related issues caused by the unchanged password shall be responsible for the user.
  - If you check the “Remember my password” option when your input is done, in future you will be logged in automatically without being prompted to enter the login information.
- 
  - If you are using Internet Explorer 7.0 or 8.0 as the default web browser, you can view the best quality image with a screen ratio of 100%. Reducing the ratio may cut the image on the borders.

# web viewer

---

This network camera uses Microsoft Silverlight for displaying the video.

## INSTALLING SILVERLIGHT RUNTIME

---

If your PC has not installed Silverlight Runtime or has just installed an old runtime version, you will be redirected to the Silverlight Runtime installation page automatically when accessing the web viewer.

1. Click **<Click Here>**.



2. When the file download dialog pops up, click **<Run>**.

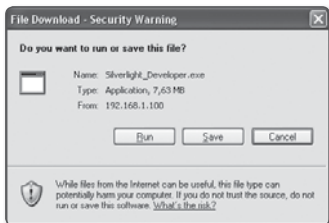

3. When the download is completed, click **<Run>**.



4. The Silverlight Runtime installation page will be displayed. **<Install now>** to proceed with the installation.



5. When done, click <Close>.



6. Close and restart the web browser, and try to access the Web Viewer. When Silverlight Runtime is properly installed, you will see the Live screen.



- For normal installation, set the Block Popup setting as follows:  
**Internet Explorer → Tools → Block Popup → Always allow popups from the current site(A)**

- However, MAC OS X users who are not connected to the Internet can use the provided installation DVD to install Silverlight Runtime (Run the executable "Silverlight\_xxx.dmg" in the DVD. You will be guided through installation of the software).



## USING THE LIVE SCREEN



Item	Description
<b>1</b> Monitoring	Move to the monitoring screen.
<b>2</b> Playback	Switch to the monitoring screen that plays recording data in the SD memory.
<b>3</b> Setup	Move to the Setup screen.
<b>4</b> Viewer Screen	Displays the Live video on the screen.
<b>5</b> Alarm Output	Activate the Alarm Out port.
<b>6</b> Audio	Display the audio Listen and Talk toggle button on the screen.
<b>7</b> Hide the alarm indicator	Hides the alarm indicator near the border of the viewer screen.
<b>8</b> Camera Menu	Used to retrieve and customize the Camera Setup menu. For selecting and saving each menu item, refer to "Using the Camera Menu". (page 67)

Item	Description
9 PTZ	You can adjust the Pan/Tilt angle of the camera as well as the zoom factor.
10 Digital PTZ	You can use the mouse wheel to activate the digital zooming.
11 Screen Optimization, Full Screen	Adjust the screen to the optimal size, and display the Full Screen icon on the Live screen.
12 Capture	Saves the snapshot as an image file in the .bmp format.
13 Video Format	<p>You can select a profile type in &lt;Video profile&gt; under the &lt;Audio &amp; Video&gt; setup menu.</p> <p><input checked="" type="checkbox"/> For IE 6.0 users, press the Browse button next to the &lt;Video profile&gt; dialog and select a profile type again if the selected profile is not played.</p> <p><input checked="" type="checkbox"/> If the "Invalid codec" message is displayed, select a profile type from the profile list again.</p>

- If the temperature drops below the operational range, video signal may not be produced. In such cases, please wait for the video.

## To capture the snapshot

- Click [  ] on the scene to capture. The Capture dialog should appear.
- Click [Save] button. The screenshot will be saved in the specified path.

- If you are using the IE8 as the default web browser, select "**Tools-Internet Options-Security**" and uncheck "**Use protected mode**".

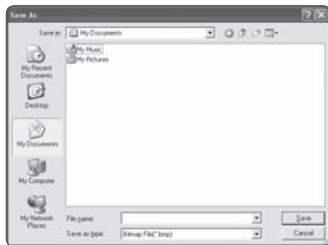

## To toggle the audio sound

1. Click the **[Audio (  )]** button.  
The corresponding button will be displayed in the Viewer.
2. Click the button to listen to / mute the sound as you wish.  
This button operates as a toggle button.



## To toggle the microphone sound

1. Click the **[Mic (  )]** button.  
The corresponding button will be displayed in the Viewer.

-  **“Cannot find audio recording device”** message appears if there is no Microphone.





2. Click the button to start / stop talking.  
This button operates as a toggle button.  
The Silverlight permission dialog appears when you click the microphone button.

## To fit the full screen

1. Click the **[Full Screen (  )]** button.  
The corresponding button will be displayed in the Viewer.
2. Click the button.  
This will fit the Viewer to the full screen.
3. To exit the full screen mode, press **[Esc]** on the keyboard.

## To control the PTZ

1. Press the **[PTZ (  )]** button.
2. When the PTZ button bar appears on the screen, use the direction buttons to adjust the camera angle, zoom factor or focus to your preference.

-  For further details on PTZ use, refer to **“PTZ setup”**. (page 83)

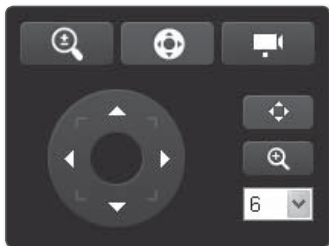





## To activate a preset



To perform the designated preset in the Live screen, right-click the mouse and select your desired preset number.

## PLAYBACK

1. Click the **[Playback (  )]** button.
2. Specify the start time and end time of your search.
3. Select a search type.
4. Click the **[Search (  )]** button.  
The search results will be displayed in the list.



- If more than 500 events are recorded within the search period, your search will be limited up to the date when the 500th event is recorded.  
For instance, if the search period is between 10th and 15th day of the month, and more than 800 events were recorded 10th through 11th, your search will be limited up to 11th day with a total of 800 events, and events after then (from 12th) will not be found.

5. Select a data item to play in the search list.
6. Click the **[Play (  )]** button.
7. To stop playing the video, click **[Stop (  )]**.  
To return to the search screen, click **[Exit (  )]**.



## To check time information of the playing video

1. Click the **[About (  )]** button.
2. Date and time information appears on the screen.

## To back up the searched video

1. Click [  ] on the scene to back up. Save as window appears.
2. Click [Save].  
The screenshot will be backed up to the specified path.



- If you are using the IE8 as the default web browser, select “Tools-Internet Options-Security” and uncheck “Use protected mode”.

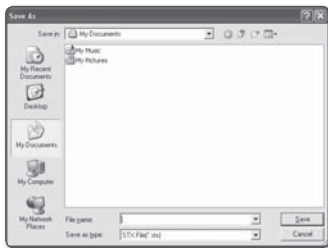

## PLAYING THE BACKUP RECORDINGS

---

You can play backup recordings by using the SlimPlayer.

### To download SlimPlayer



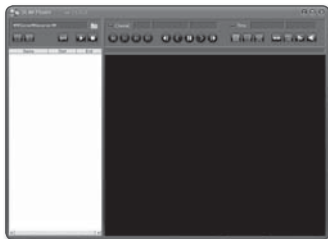
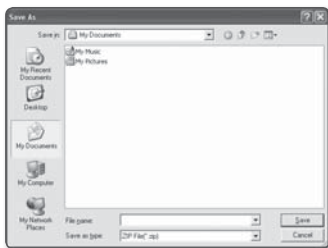

1. Click [SlimPlayer (  )].  
You will see a download dialog where you can specify the download path.
2. Specify the path with a proper file name and click [Save].
3. Unzip the downloaded file and run the executable.



# camera setup

## USING THE CAMERA MENU

Follow the steps below if you run the Web Viewer for setting the menus.

1. Launch the Web Viewer.
2. Click [**Camera Menu** (  )] in the left corner of the Live screen.  
The camera setup menu appears.
3. Use the Up/Down (▲/▼) buttons to move to a desired item.
4. Click [**Enter** (  )]. Then, use the up/down (▲/▼) button to move to a desired item.
5. To access a sub menu item, click [**Enter** (  )].
6. To move to previous menu or exit the menu setup, click [**Cancel** (  )] button.



: This arrow appears next to a menu that contains sub items.

 ■ If <IV analysis function> is enabled, camera's OSD menu operation can be set as an event.

## CAMERA SETTING

You can set up the general functions of camera module.

### Starting the Menu

1. Click [**Camera Menu** (  )] button.
2. When main menu shows up on screen, move to desired menu by using direction button.

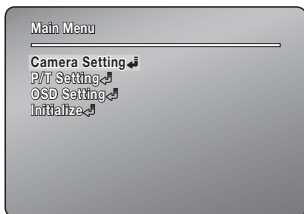

# camera setup

## Zoom/Focus

Main Menu ⇨ Camera Setting ⇨ Zoom/Focus

- Focus Mode
  - AUTO : Performs continuous auto-focus.
  - MANUAL : Changes the camera mode to Manual Focus.
  - ONESHOT : Auto-focuses the camera once after the Pan, Tilt, or Zoom function is used.
- Digital Zoom : Enables the maximum digital zoom. Setting the digital zoom to 16X provides a total zoom of 192X.

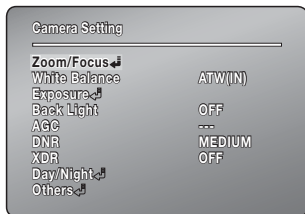

- Unlike the optical zoom, the graphics quality of the digital zoom decreases as its zoom ratio increases.
- The auto-focus function may not operate normally under the following conditions :
  - When background illumination is low
  - While Slow-Shutter is in operation
  - If the zoom level is set too high
  - When background illumination is too high
  - If a long distance object and a close distance object appear together within a monitoring area
  - If there is no contrast, e.g. Ceiling or a wall
  - If the camera is facing a thin horizontal line
- Auto Focus focuses on an object in the center of the screen; objects around the screen edges may not be properly in focus.

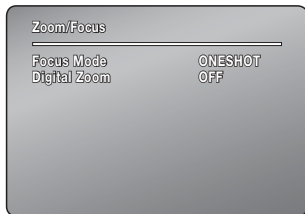

## White Balance

The White Balance menu adjusts the balance of the screen colors under different lighting conditions.

### Main Menu ⇨ Camera Setting ⇨ White Balance

- **ATW(IN)** : Adjusts the screen color to be optimal in an indoor environment. (Operating Temperature: about 2,500°K ~ about 9,300°K)
- **ATW(OUT)** : Automatically adjusts the screen color to be optimal in bright outdoors environments. (Operating Temperature: about 2,000°K ~ about 10,000°K)
- **AWC** : Adjusts the screen color to be optimized to the current lighting and monitor conditions. Using this setting may require an readjustment if the lighting conditions changes.
- **MANUAL** : Enables customization of the Red and Blue gains.

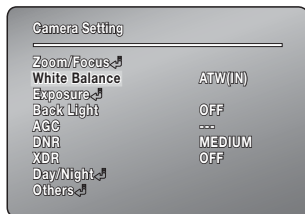

- White Balance may not work properly under the following conditions.
  - When the color temperature of the environment surrounding the subject is out of the control range.
  - When the ambient illumination of the subject is dim.
  - If the camera is directed towards a fluorescent light or is installed in a place where illumination changes dramatically, White Balance adjustments may not deliver consistent results.

# camera setup

## Exposure

The Exposure settings are to control the camera's exposure meter.

### Main Menu ⇨ Camera Setting ⇨ Exposure

- Brightness : Adjusts the screen brightness.  
(Over 32: Brighter, Under 32: Darker)
  - It may not fully operable under extremely low lighting condition.
- Iris
  - AUTO : Automatically adjusts the exposure meter.
  - MANUAL : Enables manual adjustment of the exposure meter.  
(Over 32: Brighter, Under 32: Darker)
- Shutter : Controls the camera's electronic shutter.
  - OFF : The shutter speed is fixed at 1/60 for NTSC and 1/50 for PAL.  
Operates when Iris is on the Auto Mode.
  - A. FLK : Select this setting when you experience picture flickering.  
Flickering can happen when artificial lighting frequencies clash with camera frame rates.
  - MANUAL : Enables manual adjustment of the shutter speed.
- Sens-Up
  - AUTO : Automatically detects light levels and maintains a clear picture at night or under low-light conditions.
  - Sens-Up Limit : Adjusts to the maximum-powered zoom per frame.

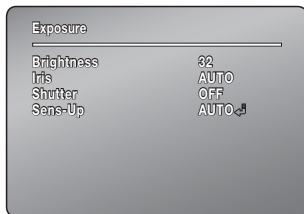
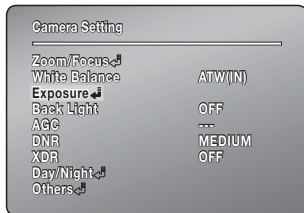

- While the Internal Sync mode is in effect, setting the shutter to '---' and facing the camera directly to a bright light source may cause poor camera performance.
- Brightness is disabled when the Iris is in Manual mode.
- Shutter is disabled when the WDR is turned on.
- Sens-Up is disabled when the shutter is in Manual mode.

## Back Light

### Backlight Mode Settings

Unlike other cameras, Samsung Techwin's unique A1 DSP chip gives you a clear image of the subject even with bright backlight.

Main Menu ⇒ Camera Setting ⇒ Back Light

- Back Light
  - OFF : Disables the Backlight mode.
  - WDR : Activates the Wide Dynamic Range mode.
  - BLC : Activates a user defined backlight compensation mode.

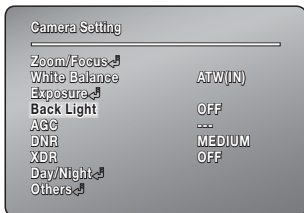

### WDR

When there are both bright and dark areas at the same time, this mode makes both areas distinctive.

Main Menu ⇒ Camera Setting ⇒ Back Light ⇒ WDR

- Limit : Three WDR sensitivity levels are available in 3 : LOW, MEDIUM, and HIGH. Note that the higher the sensitivity level, the lower the contrast in the light and dark areas becomes.
- Level : Adjusts the screen brightness in WDR mode.

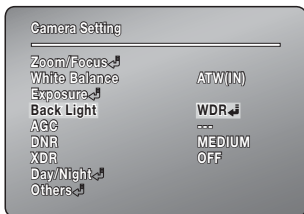

- WDR is disabled when the VPS mode is turned on.
- WDR is disabled if the Iris is in Manual mode.
- During WDR operation, noise, discoloration, spots, and whitish symptoms may occur depending on lighting conditions. If they occur, stop using WDR.

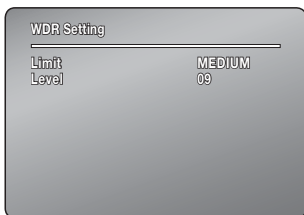

# camera setup

## BLC

You can selectively choose a screen area to see objects within the area more clearly than others.

Main Menu ⇨ Camera Setting ⇨ Back Light ⇨ BLC

- You can adjust the position and size of the backlight compensation area.



- BLC is disabled if the Iris is in Manual mode.
- Color saturation may occur depending on the environment.

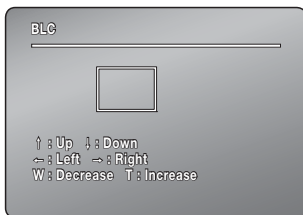
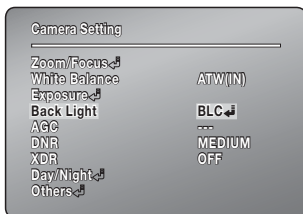

## AGC

AGC (Automatic Gain Control) adjusts the camera's gain control and the screen brightness if the camera has captured an object under low-light conditions.

Main Menu ⇨ Camera Setting ⇨ AGC

- The OFF, LOW, MEDIUM, HIGH, and MANUAL modes are available.



- If you select the AUTO for Day/Night, you cannot use the AGC menu.

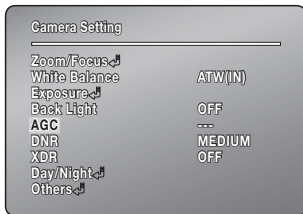



## DNR (Dynamic Noise Reduction)

DNR significantly reduces the amount of low luminance noise.

Main Menu ⇒ Camera Setting ⇒ DNR

- OFF : Disables the noise reduction function.
- LOW : Reduces only a small amount of noise, but generates almost no afterimage.
- MEDIUM : The most commonly used mode. Reduces a suitable amount of noise while generating a subtle afterimage.
- HIGH : Reduces noise significantly, but generates obvious afterimages.

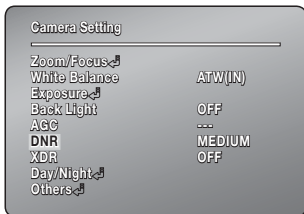

## XDR (eXtended Dynamic Range)

XDR illuminates darker spots of an image while retaining the same light level for brighter spots to even out the overall brightness of the image with high contrast between bright and dark spots.

Main Menu ⇒ Camera Setting ⇒ XDR

- The OFF, LOW, MEDIUM and HIGH modes are available.

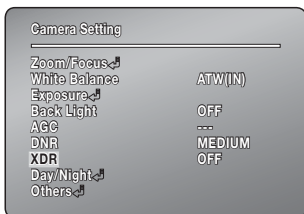

# camera setup

## Day/Night

The Day & Night function allows the camera to switch between the Color and B/W modes.

### Main Menu ⇒ Camera Setting ⇒ Day/Night

- Mode

- AUTO : Operates in Color mode most times, and switches to B/W mode if a low light level is detected during nighttime.
- COLOR : Operates in Color mode at all times.
- BW : Operates in B/W mode at all times. By using the Burst On/Off sub menu, burst signals can be retained or disabled.

- If the camera is in B/W mode and connected to equipment that requires external sync through burst signals, set the Burst On/Off option to "On".

- Dwell Time : The duration of both the lighting conditions can be customized to let the camera delay the switching between the daytime and night-time settings.



- Using B/W mode under sunlight or a halogen lamp may decrease the focusing performance.

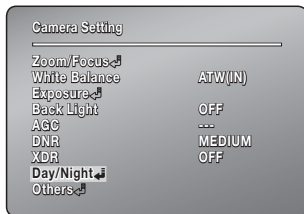

## Others

Main Menu ⇒ Camera Setting ⇒ Others

- Sharpness : Sharpens outlines of an image.
- Freeze : Stops or reanimates an image.
- Stabilizer : The Stabilizer compensates for any small movements of the camera caused by due to the wind and other reasonable causes.
- VPS : This function enhances the outline of moving subject, which improves the sharpness of a captured image as fine as a still image.
- Posi/Nega : Setting to + outputs normal video, where setting to – outputs inverted brightness and color.



- The Stabilizer uses the digital zoom and may cause low picture quality.
- The Stabilizer is disabled if the ambient light is too low.
- The Stabilizer is disabled if the field of view has very low or no contrast, e.g. The sky or a white wall.
- VPS is disabled when the Freeze is turned on.

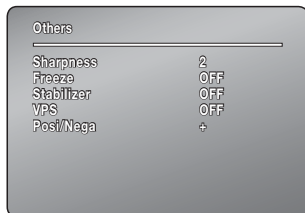
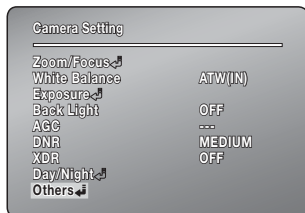

## Image Hold

Main Menu ⇒ P/T Setting ⇒ Image Hold

- When the camera is moving between presets locations, this function freezes the cameras image until the camera reached the next location. This is useful to help the screen observer keep sharp eyes and to monitor multiple locations within a network.

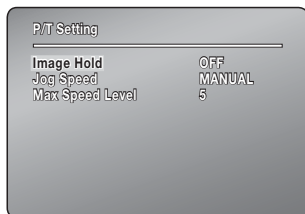

# camera setup

## Jog Speed

You can adjust the pan/tilt speed of the controller in use.

Main Menu ⇒ P/T Setting ⇒ Jog Speed

- MANUAL : The angle of the controller handle determines the speed of Pan and Tilt; the more you tilt the controller, the faster the camera spins.
- 10/20/30/40/50/60 : Maintains speed regardless of the angle of the controller handle.

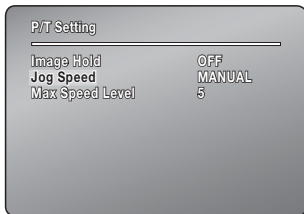

## Max Speed Level

Adjusts the maximum speed of Pan and Tilt while performing the Preset and Sequencing actions.

Main Menu ⇒ P/T Setting ⇒ Max Speed Level

- 1~7 : Pan and Tilt operations can be set up to 650°/ sec.

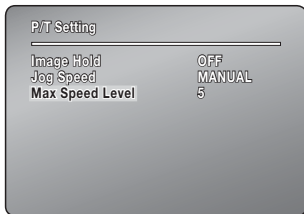

# OSD SETTING

## OSD Setting

OSD Setting is to set up the OSD (On Screen Display) functions.

### Main Menu ⇒ OSD Setting

- Camera ID : Displays or hides Camera ID in the upper left of the screen.
- Camera Name : Add a name to the camera.
- Seq. Status : Displays or hides the status of a sequence action that is in progress.
- PTZ Position : Displays or hides the status of the Pan, Tilt, and Zoom operation that is in progress.
- Language : Enables changing the system language. This camera supports English, Chinese, French, German, Spanish, Portuguese, Korean and Italian.



- When selecting the Camera Name and Preset Name, the screen displays the Left keypad.
- Names can be up to 12 characters and can be entered via the joystick and the Enter key. Once a name is entered, use the joystick and the Enter key to perform the Set command and save the name.

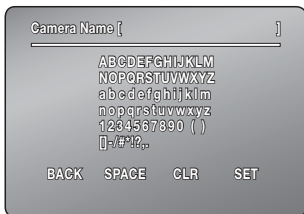
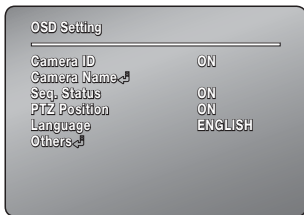
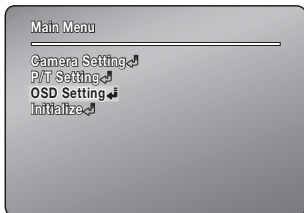

# camera setup

## OSD Setting (Others)

Main Menu ⇨ OSD Setting ⇨ Others

- Direction : Indicates the current angle of the camera: East, West, South, North, Southeast, Southwest, Northeast, or Northwest.
  - Set North Dir. : Set up a North direction for the camera.
- Clock Setting : Customize the camera clock; you can schedule sequence actions to perform automatically.
  - Display : Shows or hides the clock from the screen.
  - Date Format : Changes the display format of the camera date:  
DD/MM/YYYY or MM/DD/YYYY.

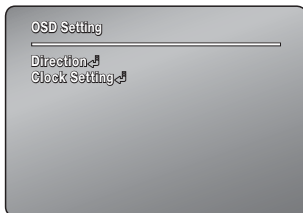
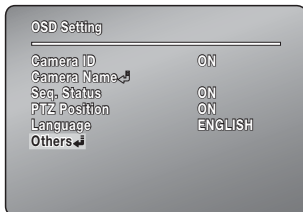

# INITIALIZE

## Initialize

Main Menu ⇨ Initialize

- Auto Refresh : Enables optimizing the status of the camera's built-in electric circuits and components on a regular basis. (A regular operation can be scheduled.) This mode can be used to maintain and repair the current settings of the camera when anomalous operations occur: e.g. The camera happened to directly face a light source, or the settings have been canceled after the camera repeatedly rotated in all four directions for a long time to monitor a specific location. The default setting is Off.
  - OFF, 1~7 Days : Selecting Off disables Auto Refresh and selecting 1~7 Days automatically executes it after 1~7 days has passed.



- Auto Refresh takes approximately 10 seconds to finish. If Auto Refresh activates in the middle of a sequence action, the camera pauses the sequence action and performs an Auto Refresh, then resumes the sequence action once the refresh is complete.

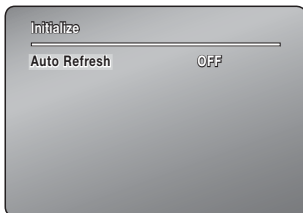
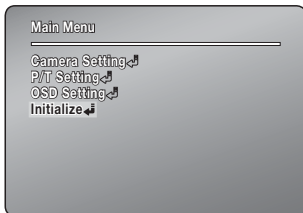

# setup screen



## SETUP

You can configure the audio & video, network, event and system settings of the camera in the network.

1. In the Live screen, click **[Setup (  )]**.
2. The Setup screen appears.

## AUDIO & VIDEO SETUP

### Video profile

1. From the Setup menu, select the **<Audio & Video (  )>** tab.
  2. Click **<Video profile>**.
  3. Select a **<Video profile>** number.
  4. Click the input box of each item and enter / select a desired value.
    - The context menu may differ depending on the selected codec type.
  - Default profile : This is the default video profile.
  - Fixed framerate profile : Fix the frame rate of the selected profile regardless of the settings of other profiles.
  - E-mail/FTP profile : Video profile to be transferred to the specified email or FTP site.
    - Only the MJPEG codec can be set as the E-mail/FTP profile.
  - Record profile : This is the profile that is applied to video recording.
5. When done, click **[Apply (  )]**.



- Profiles using H.264 codec can be stored in the SD memory only in resolutions of 640x480 or less.  
MPEG4 videos can not be stored in the SD memory.



## To add a video profile

You can add as many codecs as necessary so that a variety of profiles can be applied according to the recording condition.

1. Select a profile number.
2. Provide the name and select a codec.
3. Specify the conditions under which the codec will be applied.
4. Specify the details of the selected codec including resolution and frame rate.
  - Resolution : Set the video size of the MPEG4, H.264, and MJPEG files.
  - Framerate : Specify the frame rate.
  - Compression : Specify the compression rate of the video.
  - Bitrate control : You can select one from constant bit rate and variable bit rate for compression. Constant bit rate (CBR) varies the video quality and fixes network transfer bit rate, while variable bit rate emphasizes the quality by varying network transfer bit rate.
  - Target bitrate : Specify the bit rate at which you will transfer the video.
  - Encoding priority : You can set the video transfer method to Framerate or Compression.
  - GOP size : Select a GOP size between 1 and 15.
  - Profile : You can select the H.264 profiling method.
  - Entropy coding : Reduce the possible compression loss due to encoding.
  - Multicast(VNP) : Specify the use of the VNP protocol.
    - IPv4 : Enter an IPv4 address with which you can connect to the IPv4 network.
    - Port : Specify the video communication port.
    - TTL : Set the TTL for the VNP packet.
  - Multicast(RTP) : Specify the use of the RTP protocol.
    - IPv4 : Enter an IPv4 address with which you can connect to the IPv4 network.
    - Port : Specify the video communication port.
    - TTL : You can set the TTL for the RTP packet.

### What is GOP size?

GOP (Group of Pictures) is a set of video frames for MPEG4 and H.264 format compression, indicating a collection of frames from the initial I-Frame (key frame) to the next I-Frame. GOP consists of 2 kinds of frames: I-Frame and P-Frame.

I-Frame is the basic frame for the compression, also known as Key Frame, which contains one complete image data. P-Frame contains only the data that has changed from the preceding I-Frame.





You can set between 1 and 15 for the MPEG4 and H.264 CODEC.

# setup screen

## Video setup

### To set the privacy zone

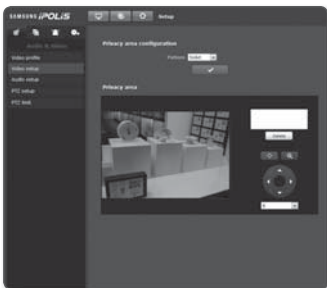

You can specify a certain area of the camera video to be protected for your privacy.

1. From the Setup menu, select the <Audio & Video (  )> tab.
2. Click <Video setup>.
3. Select a <Pattern> that will be applied to the privacy zone.
  - If you select [Solid] from the <Pattern> items, the selected zone will be displayed in grey.
  - If you select one from [P1~P3], the selected zone will be displayed in mosaic pixels.
4. Click an area on the image and select 4 corner points to specify a desired zone. A popup appears where you enter a name for the zone and click [Apply (  )].
  - Do not drag an area to specify a privacy zone; it does not work.
5. To delete the selected area, click [Delete (  )].
6. When done, click [Apply (  )].
  - You can specify up to 12 zones.



## Audio setup





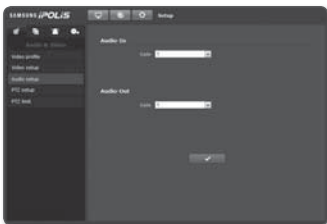







You can configure the I/O settings of the audio source from the camera.

1. From the Setup menu, select the <Audio & Video (  )> tab.
2. Click <Audio setup>.
3. Adjust the audio I/O levels to your preference.
  - Audio-In : Set the audio input value.
  - Audio-Out : Set the audio output value.
4. When done, click [Apply (  )].



## PTZ setup

You can change the direction of lens and activate the zoom.

1. Select the <Audio & Video (  )> tab from Setup menu.
2. Click <PTZ setup>.
3. Click [Direction Adjustment (  )].
  - [Change direction to (  )/(  )/(  )/(  )] : Change the direction of camera lens.
  - [Moving speed control (  )] : The bigger the number is, the faster the moving speed becomes.
4. Set the zoom and focus control buttons.
  - [Zoom In (  )] : Zooms in the screen.
  - [Zoom Out (  )] : Zooms out the screen.
  - [Adjust Focus (  /  )] : Adjusts the focus in the screen.
  - [Zoom Speed Control (  )] : The bigger the number is, the faster the zoom speed becomes.
5. Set the preset.



### To add a preset

1. Select the preset number to add.
2. Set the name for the preset.
3. Press the [  ] button.

### To delete a preset



1. Select the preset number to delete.
2. Press the [  ] button.

# setup screen

## To move a preset

1. Select a preset number that you want to move.
2. Press the [  ] button.

## To set the camera operation for the preset

1. Select the number of preset that you want to configure.
2. Press the [  ] button.
3. When the Setup window appears, select each item and set appropriately.
  - PTZ Coordinate : Set the Pan/Tilt/Zoom position of the preset.
  - Focus / Zoom : Select MANUAL/AUTO or set One Shot AF mode to OFF, or select a speed rate between 2 and 12.
  - White Balance : Set INDOOR/OUTDOOR/Manual(Red Gain, Blue Gain) as appropriate.
  - Exposure : Configure the settings for Brightness/Iris/Iris Level/SHUTTER Mode (Off, Manual, A.FLK)/Shutter Speed, Sens-up Mode(Off,ON)/Sens-up Limit.
  - BackLight : Select one from Off/WDR (WDR Level, WDR Limit)/User.
  - Day / Night, AGC : Select one from Color/Black and White/Auto.
  - Others : Set DNR (Off/Low/Middle/High)/XDR(Off/Low/Middle/High) as appropriate.
4. When done, click [Apply (  )].





## To configure the swing settings

Swing is a monitoring function that moves between two preset points and enables you to trace the motion.

1. Set <Mode> in <Sequence setup> to <Swing>.  
The menu screen will switch to the swing setting screen.
2. Select a swing setting mode.
  - Pan swing : You can set the swing monitoring only using the PAN function.
  - Tilt swing : You can set the swing monitoring only using the Tilt function.
  - Pan & Tilt swing : You can set the swing monitoring only using both PAN and Tilt functions.





3. Set **<First preset>** and **<Second preset>** to specify a swing range.
4. Set the moving speed and dwell time.
5. Press the [  ] button.  
The first preset, second preset, speed and dwell time will be saved in set mode.
6. Press the [  ] button.
7. Press the [  ] button.  
The running swing will be stop.

### To set a group

The group function enables you to group various presets before calling them in sequence. Each group can contain up to 128 presets.

1. Set **<Mode>** in **<Sequence setup>** to **<Group>**.  
The menu screen will switch to the group setting screen.



2. Select a group setting mode.
  - Group No. : Select a group number.
  - Preset No. : Select a preset number.
  - Speed : Specify the speed of movement.
  - Dwell time : Specify the duration for which an operation is kept at the preset position.
3. Press the [  ] button.  
Your settings will be entered in the right list.
4. Press the [  ] button.  
Selected group data will be deleted.

### To configure the tour settings



The tour function enables you to call groups of your presets in sequence.

1. Set **<Mode>** in **<Sequence setup>** to **<Tour>**.  
The menu screen will switch to the tour setting screen.
2. Configure the tour settings in detail.
  - Group No. : Select a group number.
  - Dwell time : Specify a waiting time before a new group is called.



# setup screen

---



3. Press the [  ] button.  
Your settings will be entered in the right list.
4. Press the [  ] button.  
Set data on the right list will be saved.
5. Press the [  ] button.  
Selected tour data will be deleted.

## To set the tracing function

Tracking remembers the trace of movements instructed using the direction button and reproduces it for your reference.

1. Set <Mode> in <Sequence setup> to <Trace & Auto Run>.  
The menu screen will switch to the PTZ tracking and Auto operation menu screen.



2. Select a tracking number.  
You can save the trace in memory within 120 seconds.  
The saving time may differ depending on the difficulty of the PTZ operation.  
The operation will be saved in memory (with the memory status displayed). When the memory is full and the "EEPROM: 000%" message appears, tracking will be terminated.
3. Press the [  ] button.  
Selected tracing number will be saved.
4. Press the [  ] button.  
Selected tracing number will be activated as set.
5. Press the [  ] button.  
Tracing will be stop.

## To set the auto run

This will perform the sequence operation that you have specified if no controller manipulation is made for a certain time.

1. Set <Mode> in <Sequence setup> to <Trace & Auto Run>.

The menu screen will switch to the PTZ tracking and Auto execution menu screen.



2. Select an auto run mode.

- Home : Automatically executes the operation to the home position.
- Preset : Automatically executes the operation to the preset number.
- Swing : Automatically executes the operation in Swing mode.
- Group : Automatically executes the operation in Group mode.
- Tour : Automatically executes the operation in Tour mode.
- Trace : Automatically executes the operation in Trace mode.
- Auto pan : Automatically executes the 360° rotation in the pan direction. Auto Pan requires two options that need your settings: tilting angle and pan speed.



3. Press the [  ] button.

## PTZ limit

You can specify restrictions on the pan or tilt function.

1. From the Setup menu, select the <Audio & Video (  )> tab.
2. Click <PTZ limit>.
3. Decide if you want to limit the PTZ operations. If so, specify the details.



- Pan / Tilt Limit : Select a mode to set between Pan limit and Tilt limit.
  - Use : Select whether to use limit in set mode.
  - [  ] : Start limit setting.
  - [  ] : The starting point will be saved.
  - [  ] : The ending point will be saved then the limit mode runs in specified range between the start point and end point respectively.

## NETWORK SETUP

### Interface



1. From the Setup menu, select the **<Network (🌐)>** tab.
2. Click **<Interface>**.
3. Set the **<Interface>** and **<IPv6 setup>** as necessary.
  - IP type : Select an IP connection type.
    - Manual : Specify the IP address, Subnet Mask, Gateway, DNS1, and DNS2.
    - DHCP : Specify the DNS1 and DNS2.
    - PPPoE : Specify the DNS1, DNS2, ID and password.
      - If you set it to **<Manual>**, you should specify the IP, Subnet Mask, Gateway, DNS 1 & 2 manually.
  - MAC address : Shows the MAC address.
  - IP address : Displays the current IP address.
  - Subnet mask : Displays the **<Subnet mask>** for the set IP.
  - Gateway : Displays the **<Gateway>** for the set IP.
  - DNS1/DNS2 : Displays the DNS(Domain Name Service) server address.
  - IPv6 use : Specify the use of IPv6.
  - IPv6 address : Obtains the IPv6 address to access the IPv6 network.
4. When done, click **[Apply (✔)]**.



-  The IP addressing system will be defaulted to DHCP. However, if the DHCP server is still not found after 1 minute, the IP system will switch to Static automatically.



## Port

1. From the Setup menu, select the <Network (  )> tab.
2. Click <Port>.
3. Type in each item in the Port menu as necessary.
  - Neither the port range between 0 and 1023 nor port 3702 is available.
  - HTTP port : HTTP port used to access the camera via the web browser.  
The default is 80(TCP).
  - VNP port : Set a port used to transfer video signals with the Samsung protocols.
  - RTSP port : Used to transfer videos in the RTSP mode; the default is 554.
  - Viewer port : Used to transfer videos to the Web Viewer; the default is 4520.
    - The port range of the Viewer is between 4502 and 4534. If the VNP port is with this effective range, the Viewer port should be specified the same as the VNP port.
4. When done, click [Apply (  )].

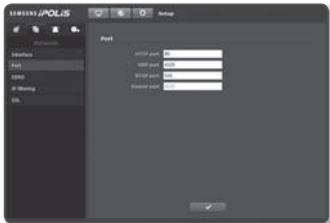

## DDNS

DDNS is an abbreviation of Dynamic Domain Name Service that converts the IP address of a camera into a general Host Name so that the user can easily remember it.

1. From the Setup menu, select the <Network (  )> tab.
2. Click <DDNS>.
3. Select <DDNS>.
4. Type in the DDNS items according to the selected type.
  - Samsung DDNS : Select this if you use the DDNS server provided by Samsung Techwin.
  - Public DDNS : Select one of provided public DDNS servers when you use a public DDNS server.
    - Host name : Enter the name of the host (i.e., host name of Dyndns) that is registered with the DDNS server.



# setup screen

- User name : Enter the user name for the DDNS service. (i.e., user ID that is registered with DynDNS)
- Password : Enter the password for the DDNS service. (i.e., password that is registered with DynDNS)

5. When done, click **[Apply (  )]**.

## Registering with DDNS

To register your product with the Samsung DDNS

1. Visit the iPOLiS web site ([www.samsungipolis.com](http://www.samsungipolis.com)) and sign in with a registered account.



2. From the top menu bar, select **<DDNS SERVICE>-<MY DDNS>**.



3. Click **[PRODUCT REGISTRATION]**.
4. Enter the product domain.
  - You must perform the duplicate check for the domain that you entered.



5. Select a <CLASSIFICATION> and specify the <MODEL NUMBER>.
6. Specify the product location with a description if necessary.
7. Click [REGISTRATION].  
The product will be added to the product list that you can check.



### To connect to the Samsung DDNS in camera setup

1. From the DDNS setup page, set <DDNS> to <Samsung DDNS>.
2. Provide the <Host name> that you registered product domain with the DDNS site.
3. Click [Apply (  )].  
When the connection is successfully made, you will see the message of <(Success)> on the screen.





### Configuring public DDNS in Camera Settings

1. Open the DDNS settings page and select <Public DDNS> for <DDNS>.
2. Enter the corresponding site's host name, user name and password.
3. Click [Apply (  )] button.  
If the connection properly establishes, <(Success)> appears.
4. When done, click [Apply (  )].

# setup screen

## IP filtering

You can create a list of IPs that you want to grant or deny access to them.

1. From the Setup menu, select the **<Network (  )>** tab.
2. Click **<IP filtering>**.
3. Select **<Filtering type>**.
  - Deny : If selecting this, access from those IPs that are added to the filtering will be restricted.
  - Allow : If selecting this, access from only those IPs that are added to the filtering will be accepted.
4. Provide the IP that you want to grant or deny access from.
5. When done, click **[Apply (  )]**.



## SSL

You can select a secure connection system or install the public certificate for this purpose.

1. From the Setup menu, select the **<Network (  )>** tab.
2. Click **<SSL>**.
3. Select a secure connection system.
  - To access the camera using HTTPS mode, you have to type the IP address for the camera in the form of "https://<Camera\_IP>".
4. Search for the public certificate that you want to install on the camera.

To install the certificate on the camera, you need to provide a certificate name (it can be arbitrarily assigned by the user), certificate file issued from the certification authority and a key file.

  - The **<HTTPS(Secure connection mode using the public certificate)>** item will be active only if there exists a public certificate installed.
5. When done, click **[Apply (  )]**.

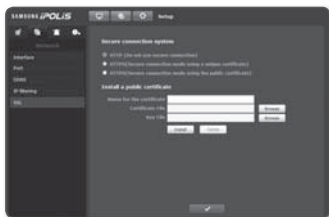

### Installing the certificate

1. Enter the certificate name.
2. Select the certificate file to be installed and certificate key, and click [**Install** (  )]

### Deleting the certificate

1. Click [**Delete** (  )]

## EVENT SETUP

### FTP / E-mail

You can configure the FTP/E-mail server settings so that you can transfer the images stored in the camera to your PC if an event occurs.

1. From the Setup menu, select the <Event (  )> tab.
2. Click <FTP / E-mail>.
3. Select <FTP configuration> or <E-mail configuration> and enter / select a desired value.
  - FTP configuration
    - Server address : Enter the IP address of the FTP server that you transfer the alarm images to.
    - User ID : Enter the user ID with which you will log in to the FTP server.
    - Password : Enter the user account password for logging into the FTP server.
    - Upload directory : Specify the FTP path where you will transfer the alarm images.
    - Port : The default port of the FTP server is 21; however, you can use a different port number according to the FTP server settings.
    - Passive mode : Select <On> if you need to connect in passive mode due to the firewall or the FTP server settings.

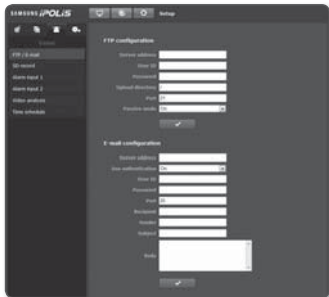

# setup screen

---

- E-mail configuration
  - Server address : Enter the IP address of the email server that you use for the email transfer.  
ex) SMTP. hotmail. com
  - Use authentication : Select whether to use authorization.
  - User ID : Enter the user ID for logging into the email server.
  - Password : Enter the user account password for logging into the email server.
  - Port : The default port of the email server is 25; however, you can use a different port number according to the email server settings.
  - Recipient : Enter the address of the email recipient.
  - Sender : Enter the address of the email sender. If the sender address is incorrect, the email from the sender may be classified as SPAM by the email server and thus may not be sent.
  - Subject : Enter a subject for your email.
  - Body : Provide the text for the message. Attach the alarm images to the email that you are preparing.

4. When done, click **[Apply (  )]**.

## SD record

You can set the record conditions or the use of recording for the SD memory, check the size of stored data, or format the SD memory itself.

1. From the Setup menu, select the **<Event (  )>** tab.
2. Click **<SD record>**.

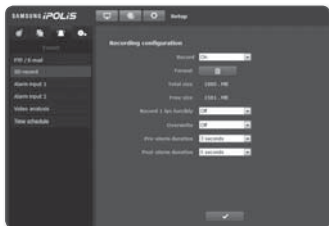



### To make recording on the SD memory

1. Check the <Total size> and the <Free size>.
2. If the SD memory has a sufficient free space, set <Record> to <On>. Otherwise, check the stored data and if you find them not important, then click <Format> to format the SD memory.
  - If your SD memory card writes slowly, only one frame per second will be stored.
  - For a SD memory card with a large capacity, the formatting will be slowed down accordingly.
  - If the size of data grows with time, only 1 fps can be stored even if you set the record quality to Full Frame.
3. Specify the record conditions.
  - Record 1 fps forcibly : Only one frame per second will be recorded regardless of the existing record profile.
  - Overwrite : If the SD memory is full, this will delete old data and store new data in replacement.
  - Pre-alarm duration : Specify the time point before the occurrence of the alarm; starting from the time point, the images will be transferred. You can specify up to 5 seconds before the occurrence of the alarm.
  - Post-alarm duration : Specify the time point after the occurrence of the alarm; to the specified time point, the images will be transferred. You can specify up to 120 seconds after the occurrence of the alarm.
4. When done, click [Apply (  )].

# setup screen

## Alarm input1/Alarm input2

You can set the alarm input type, activation time, and operation mode.

1. From the Setup menu, select the <Event (  )> tab.
2. Click <Alarm input>.
3. Specify an input device.
  - Type
    - Normal Open : It is normally open, but if it is closed, an alarm will be triggered.
    - Normal Close : It is normally closed, but if it is open, an alarm will be triggered.
4. Specify the <Activation time>.
  - Always : Always check if an alarm occurs. It activates in operated mode when the alarm occurs.
  - Only scheduled time : Check if an alarm occurs at a specified day of the week for a specified time period. It activates in operated mode when the alarm occurs.
5. Specify an operation that will perform if an alarm occurs.
  - Alarm output1/Alarm output2 : Select whether to set the alarm output if an alarm is incoming, and specify the alarm output time.
  - E-mail sending : Specify the use of email transfer in the alarm input setup.
  - Record : Specify the use of recording in the alarm input setup.
  - Goto Preset : Moves to the specified preset location when setting the alarm input.
6. When done, click [Apply (  )].

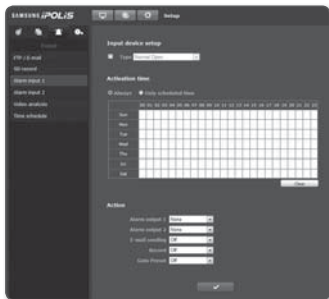



## Video analysis

1. From the Setup menu, select the <Event (  )> tab.
2. Click <Video analysis>.
3. Specify the use of Intelligent Video Analysis.
4. Set the resolution value and sensitivity level to detect an object.

Resolution Value	Object Size
1	32 of 8x8 pixel
2	24 of 8x8 pixel
3	16 of 8x8 pixel
4	8 of 8x8 pixel
5	1 of 8x8 pixel

- If you set the Resolution Value high, the camera can detect detail motion of the object.
5. Set the Motion Detection type.  
Sets to detect and trace the moving object.
    - Tracking : Detects a moving object and perform additional functions.
    - Detection : Detects a moving object.
  6. Set whether to use the Additional Motion Functions or not.  
Detects any motion of an object, displays the video with any changes, and trace the moving path.
    - If you select the <Moved/Fixed>, you can display the corresponding area when an object disappears from the screen or an object appears and stays in the screen for a specified time period.
  7. Set whether to use the Motion Display function or not.
  8. Set the activation time and condition.
    - Refer to the "Alarm input1/Alarm input2" for how to set the <Activation time> and <Action>. (page 96)
  9. Select whether to display the mask zone.  
You can set maximum of 4 mask zones. To set mask area, drag the designed area with mouse. Motion detection is not activated in set mask area. To delete set area, click [Delete (  )] button.



# setup screen



- Even if the <Video analysis> is enabled, the video analysis function does not work when entering through the operating menu in the camera.
- If camera is capturing a close object, the video analysis capability may degrade. In the following cases, the video analysis function may not produce a proper result on the default event and motion detections.
  - The object color or brightness is similar to the background
  - Multiple movements continue occurring at random due to a scene change or other reasons.
  - A fixed object continues moving in the same position.
  - An object hides other objects behind.
  - Two or more objects overlap or one object divides in multiple portions
  - Too fast object (for a proper detection, one object should be found overlapping between contiguous frames).
  - Reflection / blur / shadow due to a strong light such as direct sunlight, illumination, or headlamp
  - In severe snow, rain, wind or in dawn / dusk
  - A moving object comes close to the camera

## Time schedule

You can configure so that an event will occur at a scheduled time regardless of the actual occurrence of the event.

1. From the Setup menu, select the <Event (  )> tab.
2. Click <Time schedule>.

### To set the timer event

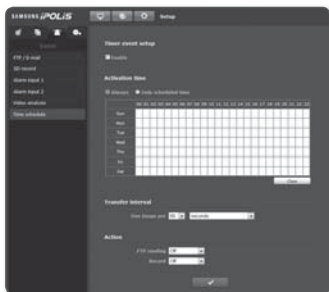

1. Set <Timer event setup> to <Enable>.
2. Specify the <Activation time>.
  - Always : Always activates in operated mode at the set interval.
  - Only scheduled time : Periodically activates in operated mode at a specified time and date.





3. Specify the <Transfer interval>.
4. Specify the activation conditions.
  - FTP sending : Specify the use of the FTP transfer if an event occurs.
  - Record : Specify the use of recording if an event occurs.
5. When done, click **[Apply (  )]**.

## SYSTEM SETUP

### Product information

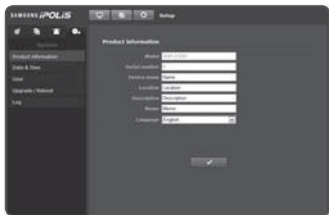

1. From the Setup menu, select the <System (  )> tab.
2. Click <Product information>.
3. Check the camera information, or provide details according to your network environment.
  - Location : Specify the location where the camera is installed.
  - Description : Provide detailed information about the camera location.
  - Memo : Provide an explanation about the camera for better understanding.
  - Language : Selects the language to display in the Web Viewer.
4. When done, click **[Apply (  )]**.



- 
  - You should change the camera menu language in camera menu.
  - Product related information only allows English for input.

# setup screen

## Date & Time

1. From the Setup menu, select the <System (  )> tab.
2. Click <Date & Time>.
3. Specify the time and date that will be applied to the camera.
  - Current system time : Displays the current time settings of your system.
  - Timezone : Specify the local time zone based on the GMT.
  - Use daylight saving time : If checked, the time will be set one hour before the local time zone for the specified time period. This option will be displayed only in areas where DST is applied.
  - System time setup : Specify the time and date that will be applied to your system.
    - Manual : Specify the time manually.
    - Synchronize with NTP server : Sync with the time of the specified server address.
    - Synchronize with PC viewer : Synchronize the time with the connected PC.
4. When done, click [Apply (  )].



-  ■ If you select the <Synchronize with PC viewer>, the standard timezone should be set the same as the current timezone in PC.

## User

1. From the Setup menu, select the <System (  )> tab.
2. Click <User>.
3. Provide the necessary user information.
  - Administrator Password Change : Change the current password for the administrator.
    - The default password can be exposed to a hacking thread so it is recommended to change the password after installing the product.Note that the security and other related issues caused by the unchanged password shall be responsible for the user.



- Guest setup : If <Guest access> is permitted, any guest can access the Web Viewer screen but can view only the Live viewer screen.
  - Current users : You can change the user information and adjust the permission level for a user who is set to <Enable>.
    - Video : You can select a video profile in the Live viewer screen.
    - Audio-In : The audio input option will be activated in the Live Viewer screen.
    - Controls : You can control the camera menu, PTZ, Mic. and Alarm button.
4. When done, click [Apply (  )].

## Upgrade / Reboot

1. From the Setup menu, select the <System (  )> tab.
2. Click <Upgrade / Reboot>.
3. Select a desired item and set it appropriately.
  - Upgrade : Performs upgrading the system.
  - Factory default : Resets the system to the factory default.
    - Except network parameter : Reset the other settings except for the interface/port/DDNS/IP filtering/SSL settings.
    - All : Resets all settings including the camera settings. (however, the log information will not be reset)
      - If you reset the camera, the network settings will be adjusted so that DHCP can be enabled. If there is no DHCP server in the network, you must run the IP Installer program to change the basic network settings such as IP address, Subnet mask, Gateway, etc., before you can connect to the network.
  - Configuration backup & Restore : Backs up the current system settings before performing the restoration process. The system is automatically restarts after backup or restoration.
  - Restart : Restarts the system.

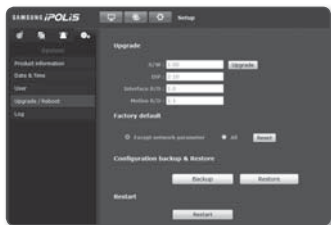

# setup screen

## To perform the upgrade

1. Click [**Upgrade**].
2. Click [**Browse**] and specify a file to upgrade.
3. Click [**Send**].
4. The “**Upgrade**” dialog appears where the progression will be shown in the bottom.

-  ■ If you forcibly terminate the upgrade process, upgrade will not be completed properly.

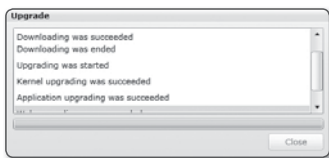
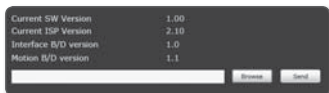

## To save the current settings and restore the backup settings

1. Click [**Backup**].  
The Save As dialog should appear.
2. Specify the backup path with a proper file name, and click [**Save**].  
The backup file will be saved to the specified path in the format of “.bin”.
3. To restore the backup settings, click [**Restore**].
4. Select a backup file and click [**Open**].

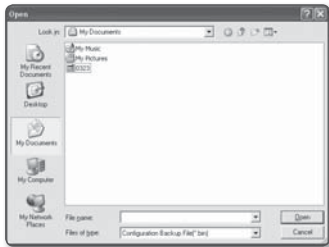
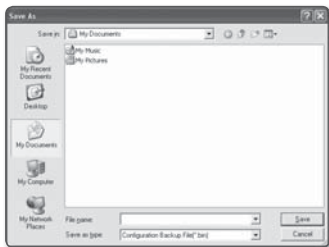

## Log

You can check the system log or event log.

1. From the Setup menu, select the <System (  )> tab.
2. Click <Log>.
3. Select a log type.
  - Syslog : You can check the system logs where any system changes are recorded including the time information.
  - Evtlog : You can check the event logs including the time information.
4. From the right log list, select an item to search for.
  - If you select <All> in the top left dropdown list, all logs for the applicable log type will be displayed.
5. If one page can not display all the logs available, use the bottom buttons to move to the previous, next, or the last item.

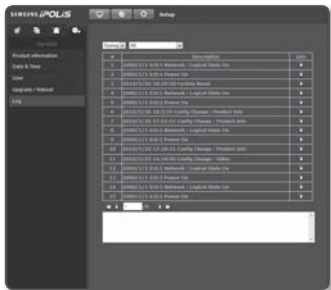

-  If you want to view the details of a log, click [Info (  )] in the right column of the log; the log information will be shown in the bottom pane.
- Each page displays 15 logs with the latest one displayed at the top.
- The event/system log list can contain up to 1000 logs; after that, the existing logs will be deleted from the oldest one each time a new log is created.

## SPECIFICATION

	Items	Description		
		SNP-3120	SNP-3120V	SNP-3120VH
Video	Imaging Device	1/4" Ex-view HAD PS CCD		
	Total Pixels	NT : 811(H) x 508(V), PAL : 795(H) x 596(V)		
	Effective Pixels	NT : 768(H) x 494(V), PAL : 752(H) x 582(V)		
	Scanning System	Progressive(VPS ON) (If WDR on, Interlaced Scan)		
	Synchronization	Internal / Line lock		
	Frequency	NT : H : 15.734KHz / V : 59.94Hz, PAL : H : 15.625KHz / V : 50Hz		
	Horizontal Resolution	Color : 600 TV lines		
	Min. Illumination	Color : 0.7 Lux (F 1.65, 50 IRE, VPS OFF), 0.001 Lux (Sens up 512X) B/W : 0.07 Lux (F 1.65, 50 IRE, VPS OFF), 0.0001 Lux (Sens up 512X)		
	S / N Ratio	50dB		
	Video Out	CVBS : 1.0 Vp-p / 75Ω composite		
Lens	Focal Length (Zoom Ratio)	3.69~44.32mm (12X)		
	Max. Aperture Ratio	F1.65(Wide) / F2.01(Tele)		
	Angular Field of View	H : 54.44°(Wide) ~ 4.62°(Tele) / V : 42.32°(Wide) ~ 3.58°(Tele)		
	Min. Object Distance	0.2m (Wide) / 0.8m (Tele)		
	Focus Control	AF / One-Shot AF / Manual		
	Zoom Movement Speed	-		
	Lens Type	DC Auto Iris		
	Mount Type	-		



Items		Description		
		SNP-3120	SNP-3120V	SNP-3120VH
Pan / Tilt / Rotate	Pan Range	360° Endless		
	Pan Speed	Preset : 650°/sec, Manual : 0.05°/sec ~120°/sec (Turbo:200°/sec)		
	Tilt Range	-5° ~185°		
	Tilt Speed	Preset : 650°/sec, Manual : 0.05°/sec ~120°/sec		
	Rotate Range	-		
	Preset	255 ea		
	Preset Accuracy	±0.1°		
	Auto Tracking	-		
Operational	On Screen Display	NT : English, French, German, Spanish, Italian, Korean, Portuguese PAL : English, French, German, Spanish, Italian, Chinese, Portuguese		
	Camera Title	Off / On (Displayed up to 12 characters)		
	Day & Night	Auto (ICR) / Color / B/W		
	Backlight Compensation	Off / BLC / WDR		
	Wide Dynamic Range	NT : 128X / PAL : 160X		
	Dynamic Range	XDR (eXtended Dynamic Range) (Off/Low/Medium/High)		
	Digital Noise Reduction	Motion Adaptive 2D+3D Noise Filter (Off/Low/Medium/High)		
	Digital Image Stabilization	Off / On		
	Motion Detection	Yes		
	Privacy Masking	Off / On (12 Polygonal programmable zones)		
	Sens-up (Frame Integration)	Off / Auto (2X ~ 512X)		

# appendix

Items		Description		
		SNP-3120	SNP-3120V	SNP-3120VH
Operational	Gain Control	Off / Low / Medium / High / Manual		
	White Balance	ATW (In) / ATW (Out) / AWC / Manual		
	Electronic Shutter Speed	Off / A.FLK / Manual (1/120 ~ 1/10Ksec)		
	Digital Zoom	16X		
	Flip / Mirror	Digital Flip		
	Profile	-		
	VPS	Off / On		
	Intelligent Video Analytics	Moved / Fixed		
	PIP	-		
	Schedule	-		
	Alarm I/O	Input 2ea / Output 2ea (Relay)		
	RS-485 Protocol	SAMSUNG T/E, PELCO-P/D, Panasonic, Honeywell, AD, Vicon, GE, Bosch		
Network	Ethernet	RJ-45 (10/100BASE-T)		
	Video Compression Format	H.264, MPEG4, MJPEG		
	Resolution	NT : 704x480, 640x480, 352x240, 320x240 PAL : 704x576, 640x480, 352x288, 320x240		
	Max. Framerate	NT : 30fps / PAL : 25fps		

Items	Description			
	SNP-3120	SNP-3120V	SNP-3120VH	
Network	<b>Video Quality Adjustment</b>	H.264/MPEG4 : Compression Level, Target Bitrate Level Control MJPEG : Quality Level Control		
	<b>Bitrate Control Method</b>	H.264/MPEG4 : CBR or VBR MJPEG : VBR		
	<b>Streaming Capability</b>	Multiple Streaming (Up to 10 Profiles)		
	<b>Audio I/O</b>	Line in / Line out		
	<b>Audio Compression Format</b>	G.711 $\mu$ -law		
	<b>Audio Communication</b>	2-Way		
	<b>IP</b>	IPv4, IPv6		
	<b>Protocol</b>	TCP/IP, UDP/IP, RTP(UDP), RTP(TCP), RTSP, NTP, HTTP, HTTPS, SSL, DHCP, PPPoE, FTP, SMTP, ICMP, IGMP, SNMPv1/v2c/v3(MIB-2), ARP, DNS, DDNS		
	<b>Security</b>	HTTPS(SSL) Login Authentication Digest Login Authentication IP Address Filtering User access Log		
	<b>Streaming Method</b>	Unicast / Multicast		
	<b>Max. User Access</b>	10 users at Unicast Mode		
	<b>Memory Slot</b>	SD/SDHC Memory Slot		
	<b>ONVIF Conformance</b>	Yes		
	<b>Web Viewer</b>	Supported OS : Windows XP / VISTA / 7, MAC OS Supported Browser : Internet Explorer 6.0 or Higher, Firefox, Google Chrome, Apple Safari		
<b>Central Management Software</b>	NET-i viewer			

# appendix

Items		Description		
		SNP-3120	SNP-3120V	SNP-3120VH
Environmental	Operating Temperature / Humidity	-10°C ~ +50°C (+14°F ~ +122°F) /~90% RH	-50°C ~ +50°C (-58°F ~ +122°F) / ~90% RH	
	Ingress Protection	-	IP66	
Electrical	Input Voltage / Current	24V AC, hPoE(IEEE802.3at)		
	Power Consumption	Max. 15W	Max. 15W (Heater Off), Max. 45W (Heater On)	
Mechanical	Color / Material	Body : Ivory / Plastic	Body : Ivory / Aluminum (Vandal Resistance)	Body : Ivory / Aluminum (Vandal Resistance), Sun-Shield Built-in
	Dimension (Ø x H)	Ø174.0 x H168.0 mm (6.85" x 6.61")	Ø165.0 x H165.0 mm (6.5" x 6.5")	Ø200.0 x H203.0 mm (7.87" x 7.99")
	Weight	1.2Kg (2.65 lb)	1.9Kg (4.19 lb)	2.4Kg (5.29 lb)

## PRODUCT OVERVIEW

### ❖ SNP-3120

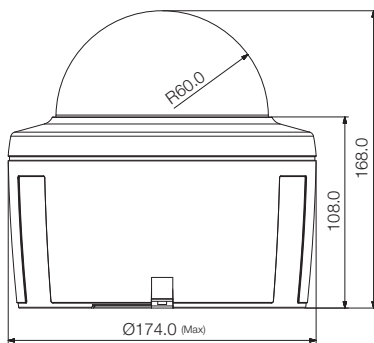

### ❖ SNP-3120V

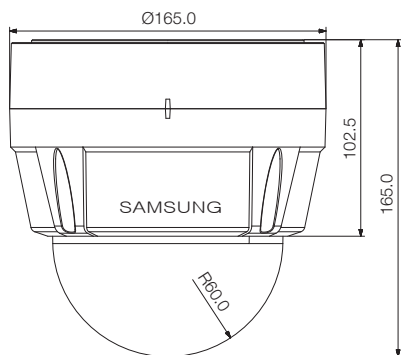

## ❖ SNP-3120VH

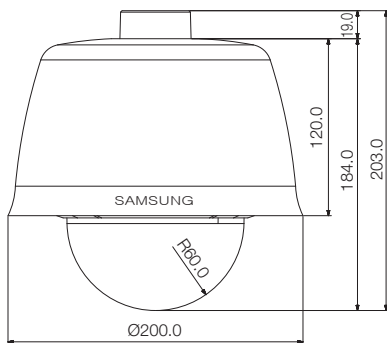

## TROUBLESHOOTING

PROBLEM	SOLUTION
<p><b>I can't access the camera from a web browser.</b></p>	<ul style="list-style-type: none"> <li>• Check to make sure that the camera's Network settings are appropriate.</li> <li>• Check to make sure that all network cables have been connected properly.</li> <li>• If connected using DHCP, verify that the camera is able to acquire dynamic IP addresses without any problem.</li> <li>• If connected using a DDNS URL, verify that the MAC address has been properly entered.</li> <li>• If the camera is connected to a router, verify that port forwarding is properly configured.</li> </ul>
<p><b>Viewer got disconnected during monitoring.</b></p>	<ul style="list-style-type: none"> <li>• Connected Viewers become disconnected upon any change to camera or network configurations.</li> <li>• Check all network connections.</li> <li>• If the camera is connected over an PPPoE network, it's possible for Viewer to disconnect under poor network conditions.</li> </ul>
<p><b>I cannot connect to the system using a tab browser of Internet Explorer 7.0.</b></p>	<ul style="list-style-type: none"> <li>• When you try to connect to the system using a tab browser, the same cookie information is shared, resulting in errors when connected. Therefore, instead of using a tab browser, open a new browser window to connect to the system.</li> </ul>
<p><b>The camera connected to the network is not detected in the IP installer program.</b></p>	<ul style="list-style-type: none"> <li>• Turn off the firewall settings on your PC and then search the camera again.</li> </ul>
<p><b>Images overlap.</b></p>	<ul style="list-style-type: none"> <li>• Check whether two or more cameras are set to a single multicast address instead of different addresses. If a single address is used for multiple cameras, the images may overlap.</li> </ul>
<p><b>No image appears.</b></p>	<ul style="list-style-type: none"> <li>• If the transmission method is set to multicast, check whether there is a router that supports multicast in the LAN the camera is connected to.</li> </ul>

# appendix

PROBLEM	SOLUTION
<b>No JPEG file is transferred via e-mail on occurrence of intelligent video analysis event of camera even when the &lt;IV analysis function&gt; is set to &lt;Enable&gt;.</b>	<ul style="list-style-type: none"><li>• Verify the settings in the following sequence:<ol style="list-style-type: none"><li>A. Check &lt;Data &amp; Time&gt; settings.</li><li>B. The &lt;IV analysis function&gt; should be set to &lt;Enable&gt;.</li><li>C. Alarm Video Transmission must be enabled.</li></ol></li></ul>
<b>Can &lt;Set Rules&gt; be configured even when the &lt;IV analysis function&gt; is set to &lt;Disable&gt;?</b>	<ul style="list-style-type: none"><li>• Yes, it can be. You can set rules for events despite of the intelligent video analysis setting.</li></ul>
<b>No signal is found at the Alarm Output port even when an intelligent video analysis event is generated.</b>	<ul style="list-style-type: none"><li>• Check alarm output port settings.</li></ul>
<b>Cannot record into the SD memory card.</b>	<ul style="list-style-type: none"><li>• Check if the memory card is defective.</li><li>• Check if the write protection tab of the memory card is set to "LOCK".</li></ul>
<b>SD memory card is inserted but the camera does not operate properly.</b>	<ul style="list-style-type: none"><li>• Check if the memory card is inserted in the proper direction. Operation of memory card that is formatted by other devices is not guaranteed with this camera unit</li><li>• Format the memory card again in &lt;Setup&gt; → &lt;Event&gt; → &lt;SD Record&gt; menu.</li></ul>
<b>Cannot format the SD memory card.</b>	<ul style="list-style-type: none"><li>• Check if the write protection tab of the memory card is set to "LOCK".</li></ul>



# OPEN SOURCE ANNOUNCEMENT

---

Some software components of this product incorporate source code covered under the BSD license as follows.

Component Name	License	License URL
lighttpd 1.4.25	BSD 2.0	<a href="http://www.opensource.org/licenses/bsd-license.html">http://www.opensource.org/licenses/bsd-license.html</a>
librtsp 1.20	BSD 1.0	

lighttpd is a secure, fast, compliant, and very flexible web-server that has been optimized for high-performance environments. It has a very low memory footprint compared to other webservers and takes care of cpu-load. Its advanced feature-set (FastCGI, CGI, Auth, Output-Compression, URL-Rewriting and many more) make lighttpd the perfect webserver-software for every server that suffers load problems.

For more additional information, send email to [help.cctv@samsung.com](mailto:help.cctv@samsung.com).

## Copyright (C) 2004, Kneschke, incremental

All rights reserved.

Redistribution and use in source and binary forms, with or without modification, are permitted provided that the following conditions are met :

- Redistributions of source code must retain the above copyright notice, this list of conditions and the following disclaimer.
- Redistributions in binary form must reproduce the above copyright notice, this list of conditions and the following disclaimer in the documentation and/or other materials provided with the distribution.
- Neither the name of the 'incremental' nor the names of its contributors may be used to endorse or promote products derived from this software without specific prior written permission.

THIS SOFTWARE IS PROVIDED BY THE COPYRIGHT HOLDERS AND CONTRIBUTORS "AS IS" AND ANY EXPRESS OR IMPLIED WARRANTIES, INCLUDING, BUT NOT LIMITED TO, THE IMPLIED WARRANTIES OF MERCHANTABILITY AND FITNESS FOR A PARTICULAR PURPOSE ARE DISCLAIMED. IN NO EVENT SHALL THE COPYRIGHT OWNER OR CONTRIBUTORS BE LIABLE FOR ANY DIRECT, INDIRECT, INCIDENTAL, SPECIAL, EXEMPLARY, OR CONSEQUENTIAL DAMAGES (INCLUDING, BUT NOT LIMITED TO, PROCUREMENT OF SUBSTITUTE GOODS OR SERVICES; LOSS OF USE, DATA, OR PROFITS; OR BUSINESS INTERRUPTION) HOWEVER CAUSED AND ON ANY THEORY OF LIABILITY, WHETHER IN CONTRACT, STRICT LIABILITY, OR TORT (INCLUDING NEGLIGENCE OR OTHERWISE) ARISING IN ANY WAY OUT OF THE USE OF THIS SOFTWARE, EVEN IF ADVISED OF THE POSSIBILITY OF SUCH DAMAGE.

## Copyright (c) 1998-2001 University College London

All rights reserved.

Redistribution and use in source and binary forms, with or without modification, is permitted provided that the following conditions are met :

1. Redistributions of source code must retain the above copyright notice, this list of conditions and the following disclaimer.
2. Redistributions in binary form must reproduce the above copyright notice, this list of conditions and the following disclaimer in the documentation and/or other materials provided with the distribution.
3. All advertising materials mentioning features or use of this software must display the following acknowledgement: This product includes software developed by the Computer Science Department at University College London.
4. Neither the name of the University nor of the Department may be used to endorse or promote products derived from this software without specific prior written permission.

THIS SOFTWARE IS PROVIDED BY THE AUTHORS AND CONTRIBUTORS "AS IS" AND ANY EXPRESSED OR IMPLIED WARRANTIES, INCLUDING, BUT NOT LIMITED TO, THE IMPLIED WARRANTIES OF MERCHANTABILITY AND FITNESS FOR A PARTICULAR PURPOSE ARE DISCLAIMED. IN NO EVENT SHALL THE AUTHORS OR CONTRIBUTORS BE LIABLE FOR ANY DIRECT, INDIRECT, INCIDENTAL, SPECIAL, EXEMPLARY, OR CONSEQUENTIAL DAMAGES (INCLUDING, BUT NOT LIMITED TO, PROCUREMENT OF SUBSTITUTE GOODS OR SERVICES; LOSS OF USE, DATA, OR PROFITS; OR BUSINESS INTERRUPTION) HOWEVER CAUSED AND ON ANY THEORY OF LIABILITY, WHETHER IN CONTRACT, STRICT LIABILITY, OR TORT (INCLUDING NEGLIGENCE OR OTHERWISE) ARISING IN ANY WAY OUT OF THE USE OF THIS SOFTWARE, EVEN IF ADVISED OF THE POSSIBILITY OF SUCH DAMAGE.

# GPL/LGPL SOFTWARE LICENSE

---

The software included in this product contains copyrighted software that is licensed under the GPL/LGPL. You may obtain the complete Corresponding Source code from us for a period of three years after our last shipment of this product by sending email to help.cctv@samsung.com

If you want to obtain the complete Corresponding Source code in the physical medium such as CD-ROM, the cost of physically performing source distribution might be charged.

- GPL S/W
    - Base Kernel, Busybox, Sysvinit, dosfstools
  - LGPL S/W
    - gLibc, lnetutils
- 

## GNU GENERAL PUBLIC LICENSE

Version 2, June 1991

Copyright (C)1989, 1991 Free Software Foundation, Inc.

51 Franklin Street, Fifth Floor, Boston, MA 02110-1301, USA

Everyone is permitted to copy and distribute verbatim copies of this license document, but changing it is not allowed.

### Preamble

The licenses for most software are designed to take away your freedom to share and change it. By contrast, the GNU General Public License is intended to guarantee your freedom to share and change free software-- to make sure the software is free for all its users.

This General Public License applies to most of the Free Software Foundation's software and to any other program whose authors commit to using it. (Some other Free Software Foundation software is covered by the GNU Lesser General Public License instead.) You can apply it to your programs, too.

When we speak of free software, we are referring to freedom, not price.

Our General Public Licenses are designed to make sure that you have the freedom to distribute copies of free software (and

charge for this service if you wish), that you receive source code or can get it if you want it, that you can change the software or use pieces of it in new free programs ; and that you know you can do these things.

To protect your rights, we need to make restrictions that forbid anyone to deny you these rights or to ask you to surrender the rights. These restrictions translate to certain responsibilities for you if you distribute copies of the software, or if you modify it.

For example, if you distribute copies of such a program, whether gratis or for a fee, you must give the recipients all the rights that you have.

You must make sure that they, too, receive or can get the source code. And you must show them these terms so they know their rights.

We protect your rights with two steps :

(1)copyright the software, and (2)offer you this license which gives you legal permission to copy, distribute and/or modify the software.

Also, for each author's protection and ours, we want to make certain that everyone understands that there is no warranty for this free software. If the software is modified by someone else and passed on, we want its recipients to know that what they have is not the original, so that any problems introduced by others will not reflect on the

original authors' reputations.

Finally, any free program is threatened constantly by software patents. We wish to avoid the danger that redistributors of a free program will individually obtain patent licenses, in effect making the program proprietary. To prevent this, we have made it clear that any patent must be licensed for everyone's free use or not licensed at all.

The precise terms and conditions for copying, distribution and modification follow.

## **TERMS AND CONDITIONS FOR COPYING, DISTRIBUTION AND MODIFICATION**

Version 2, June 1991 Copyright (C) 1989, 1991 Free Software Foundation, Inc. 51 Franklin S

0. This License applies to any program or other work which contains a notice placed by the copyright holder saying it may be distributed under the terms of this General Public License.

The "Program", below, refers to any such program or work, and a "work based on the Program" means either the Program or any derivative work under copyright law : that is to say, a work containing the Program or a portion of it, either verbatim or with modifications and/or translated into another language. (Hereinafter, translation is included without limitation in the term "modification".) Each licensee is addressed as "you".

Activities other than copying, distribution and modification are not covered by this License ; they are outside its scope. The act of running the Program is not restricted, and the output from the Program is covered only if its contents constitute a work based on the Program (independent of having been made by running the Program). Whether that is true depends on what the Program does.

1. You may copy and distribute verbatim copies of the Program's source code as

you receive it, in any medium, provided that you conspicuously and appropriately publish on each copy an appropriate copyright notice and disclaimer of warranty; keep intact all the notices that refer to this License and to the absence of any warranty ; and give any other recipients of the Program a copy of this License along with the Program.

You may charge a fee for the physical act of transferring a copy, and you may at your option offer warranty protection in exchange for a fee.

2. You may modify your copy or copies of the Program or any portion of it, thus forming a work based on the Program, and copy and distribute such modifications or work under the terms of Section 1 above, provided that you also meet all of these conditions :

- a) You must cause the modified files to carry prominent notices stating that you changed the files and the date of any change.
- b) You must cause any work that you distribute or publish, that in whole or in part contains or is derived from the Program or any part thereof, to be licensed as a whole at no charge to all third parties under the terms of this License.
- c) If the modified program normally reads commands interactively when run, you must cause it, when started running for such interactive use in the most ordinary way, to print or display an announcement including an appropriate copyright notice and a notice that there is no warranty (or else, saying that you provide a warranty) and that users may redistribute the program under these conditions, and telling the user how to view a copy of this License. (Exception:if the Program itself is interactive but does not normally print such an announcement, your work

based on the Program is not required to print an announcement.)

These requirements apply to the modified work as a whole. If identifiable sections of that work are not derived from the Program, and can be reasonably considered independent and separate works in themselves, then this License, and its terms, do not apply to those sections when you distribute them as separate works. But when you distribute the same sections as part of a whole which is a work based on the Program, the distribution of the whole must be on the terms of this License, whose permissions for other licensees extend to the entire whole, and thus to each and every part regardless of who wrote it.

Thus, it is not the intent of this section to claim rights or contest your rights to work written entirely by you ; rather, the intent is to exercise the right to control the distribution of derivative or collective works based on the Program. In addition, mere aggregation of another work not based on the Program with the Program (or with a work based on the Program) on a volume of a storage or distribution medium does not bring the other work under the scope of this License.

3. You may copy and distribute the Program (or a work based on it, under Section 2) in object code or executable form under the terms of Sections 1 and 2 above provided that you also do one of the following :

- a) Accompany it with the complete corresponding machine-readable source code, which must be distributed under the terms of Sections 1 and 2 above on a medium customarily used for software interchange ; or,
- b) Accompany it with a written offer, valid for at least three years, to give any third party, for a charge no more than your cost of physically

performing source distribution, a complete machine-readable copy of the corresponding source code, to be distributed under the terms of Sections 1 and 2 above on a medium customarily used for software interchange ; or,

- c) Accompany it with the information you received as to the offer to distribute corresponding source code. (This alternative is allowed only for noncommercial distribution and only if you received the program in object code or executable form with such an offer, in accord with Subsection b above.)

The source code for a work means the preferred form of the work for making modifications to it. For an executable work, complete source code means all the source code for all modules it contains, plus any associated interface definition files, plus the scripts used to control compilation and installation of the executable. However, as a special exception, the source code distributed need not include anything that is normally distributed (in either source or binary form) with the major components (compiler, kernel, and so on) of the operating system on which the executable runs, unless that component itself accompanies the executable.

If distribution of executable or object code is made by offering access to copy from a designated place, then offering equivalent access to copy the source code from the same place counts as distribution of the source code, even though third parties are not compelled to copy the source along with the object code.

4. You may not copy, modify, sublicense, or distribute the Program except as expressly provided under this License. Any attempt otherwise to copy, modify, sublicense or distribute the Program is void, and will automatically terminate your rights under this License.

However, parties who have received copies, or rights, from you under this License will not have their licenses terminated so long as such parties remain in full compliance.

5. You are not required to accept this License, since you have not signed it. However, nothing else grants you permission to modify or distribute the Program or its derivative works. These actions are prohibited by law if you do not accept this License. Therefore, by modifying or distributing the Program (or any work based on the Program), you indicate your acceptance of this License to do so, and all its terms and conditions for copying, distributing or modifying the Program or works based on it.
6. Each time you redistribute the Program (or any work based on the Program), the recipient automatically receives a license from the original licensor to copy, distribute or modify the Program subject to these terms and conditions. You may not impose any further restrictions on the recipients' exercise of the rights granted herein. You are not responsible for enforcing compliance by third parties to this License.
7. If, as a consequence of a court judgment or allegation of patent infringement or for any other reason (not limited to patent issues), conditions are imposed on you (whether by court order, agreement or otherwise) that contradict the conditions of this License, they do not excuse you from the conditions of this License. If you cannot distribute so as to satisfy simultaneously your obligations under this License and any other pertinent obligations, then as a consequence you may not distribute the Program at all. For example, if a patent license would not permit royalty-free redistribution of the Program by all those who receive copies directly or indirectly through you,

then the only way you could satisfy both it and this License would be to refrain entirely from distribution of the Program.

If any portion of this section is held invalid or unenforceable under any particular circumstance, the balance of the section is intended to apply and the section as a whole is intended to apply in other circumstances. It is not the purpose of this section to induce you to infringe any patents or other property right claims or to contest validity of any such claims; this section has the sole purpose of protecting the integrity of the free software distribution system, which is implemented by public license practices. Many people have made generous contributions to the wide range of software distributed through that system in reliance on consistent application of that system; it is up to the author/donor to decide if he or she is willing to distribute software through any other system and a licensee cannot impose that choice.

This section is intended to make thoroughly clear what is believed to be a consequence of the rest of this License.

8. If the distribution and/or use of the Program is restricted in certain countries either by patents or by copyrighted interfaces, the original copyright holder who places the Program under this License may add an explicit geographical distribution limitation excluding those countries, so that distribution is permitted only in or among countries not thus excluded. In such case, this License incorporates the limitation as if written in the body of this License.
9. The Free Software Foundation may publish revised and/or new versions of the General Public License from time to time. Such new versions will be similar in spirit to the present version, but may differ in detail to address new problems or concerns.

Each version is given a distinguishing version number. If the Program specifies

a version number of this License which applies to it and "any later version", you have the option of following the terms and conditions either of that version or of any later version published by the Free Software Foundation. If the Program does not specify a version number of this License, you may choose any version ever published by the Free Software Foundation.

10. If you wish to incorporate parts of the Program into other free programs whose distribution conditions are different, write to the author to ask for permission. For software which is copyrighted by the Free Software Foundation, write to the Free Software Foundation; we sometimes make exceptions for this. Our decision will be guided by the two goals of preserving the free status of all derivatives of our free software and of promoting the sharing and reuse of software generally.

## **NO WARRANTY**

11. BECAUSE THE PROGRAM IS LICENSED FREE OF CHARGE, THERE IS NO WARRANTY FOR THE PROGRAM, TO THE EXTENT PERMITTED BY APPLICABLE LAW. EXCEPT WHEN OTHERWISE STATED IN WRITING THE COPYRIGHT HOLDERS AND/OR OTHER PARTIES PROVIDE THE PROGRAM "AS IS" WITHOUT WARRANTY OF ANY KIND, EITHER EXPRESSED OR IMPLIED, INCLUDING, BUT NOT LIMITED TO, THE IMPLIED WARRANTIES OF MERCHANTABILITY AND FITNESS FOR A PARTICULAR PURPOSE. THE ENTIRE RISK AS TO THE QUALITY AND PERFORMANCE OF THE PROGRAM IS WITH YOU. SHOULD THE PROGRAM PROVE DEFECTIVE, YOU ASSUME THE COST OF ALL NECESSARY SERVICING, REPAIR OR CORRECTION.
12. IN NO EVENT UNLESS REQUIRED BY APPLICABLE LAW OR AGREED

TO IN WRITING WILL ANY COPYRIGHT HOLDER, OR ANY OTHER PARTY WHO MAY MODIFY AND/OR REDISTRIBUTE DAMAGES, INCLUDING ANY GENERAL, SPECIAL, INCIDENTAL OR CONSEQUENTIAL DAMAGES ARISING OUT OF THE USE OR INABILITY TO USE THE PROGRAM (INCLUDING BUT NOT LIMITED TO LOSS OF DATA OR DATA BEING RENDERED INACCURATE OR LOSSES SUSTAINED BY YOU OR THIRD PARTIES OR A FAILURE OF THE PROGRAM TO OPERATE WITH ANY OTHER PROGRAMS), EVEN IF SUCH HOLDER OR OTHER PARTY HAS BEEN ADVISED OF THE POSSIBILITY OF SUCH DAMAGES.

## **END OF TERMS AND CONDITIONS**

### **How to Apply These Terms to Your New Programs**

If you develop a new program, and you want it to be of the greatest possible use to the public, the best way to achieve this is to make it free software which everyone can redistribute and change under these terms.

To do so, attach the following notices to the program. It is safest to attach them to the start of each source file to most effectively convey the exclusion of warranty; and each file should have at least the "copyright" line and a pointer to where the full notice is found.

one line to give the program's name and an idea of what it does.

Copyright (C)yyyy name of author

This program is free software; you can redistribute it and/or modify it under the terms of the GNU General Public License as published by the Free Software Foundation; either version 2 of the License, or (at your option) any later version.

This program is distributed in the hope that it will be useful, but WITHOUT ANY

WARRANTY ; without even the implied warranty of MERCHANTABILITY or FITNESS FOR A PARTICULAR PURPOSE. See the GNU General Public License for more details.

You should have received a copy of the GNU General Public License along with this program ; if not, write to the Free Software Foundation, Inc.,51 Franklin Street, Fifth Floor, Boston, MA 02110-1301, USA.

Also add information on how to contact you by electronic and paper mail. If the program is interactive, make it output a short notice like this when it starts in an interactive mode :

Gnomovision version 69,

Copyright (C) year name of author

Gnomovision comes with ABSOLUTELY NO

WARRANTY ; for details type 'show w'.

This is free software, and you are welcome to redistribute it under certain conditions ; type 'show c' for details.

The hypothetical commands 'show w' and 'show c' should show the appropriate parts of the General Public License. Of course, the commands you use may be called something other than 'show w' and 'show c' ; they could even be mouse-clicks or menu items-- whatever suits your program.

You should also get your employer (if you work as a programmer) or your school, if any, to sign a "copyright disclaimer" for the program, if necessary. Here is a sample ; after the names:

Yoyodyne, Inc., hereby disclaims all copyright interest in the program 'Gnomovision' (which makes passes at compilers) written by James Hacker.

signature of Ty Coon, 1 April 1989 Ty Coon, President of Vice This General Public License does not permit incorporating your program into proprietary programs. If your

program is a subroutine library, you may consider it more useful to permit linking proprietary applications with the library. If this is what you want to do, use the **GNU Lesser General Public License** instead of this License.

## GNU GENERAL PUBLIC LICENSE

Version 3, 29 June 2007

Copyright © 2007 Free Software Foundation, Inc. <<http://fsf.org/>>

Everyone is permitted to copy and distribute verbatim copies of this license document, but changing it is not allowed.

### Preamble

The GNU General Public License is a free, copyleft

license for software and other kinds of works. The licenses for most software and other practical works are designed to take away your freedom to share and change the works. By contrast, the GNU General Public License is intended to guarantee your freedom to share and change all versions of a program--to make sure it remains free software for all its users.

We, the Free Software Foundation, use the GNU General Public License for most of our software; it applies also to any other work released this way by its authors. You can apply it to your programs, too.

When we speak of free software, we are referring to freedom, not price. Our General Public Licenses are designed to make sure that you have the freedom to distribute copies of free software (and charge for them if you wish), that you receive source code or can get it if you want it, that you can change the software or use pieces of it in new free programs, and that you know you can do these things.

To protect your rights, we need to prevent others from denying you these rights



or asking you to surrender the rights. Therefore, you have certain responsibilities if you distribute copies of the software, or if you modify it: responsibilities to respect the freedom of others.

For example, if you distribute copies of such a program, whether gratis or for a fee, you must pass on to the recipients the same freedoms that you received. You must make sure that they, too, receive or can get the source code. And you must show them these terms so they know their rights.

Developers that use the GNU GPL protect your rights with two steps: (1) assert copyright on the software, and (2) offer you this License giving you legal permission to copy, distribute and/or modify it.

For the developers' and authors' protection, the GPL clearly explains that there is no warranty for this free software. For both users' and authors' sake, the GPL requires that modified versions be marked as changed, so that their problems will not be attributed erroneously to authors of previous versions.

Some devices are designed to deny users access to install or run modified versions of the software inside them, although the manufacturer can do so. This is fundamentally incompatible with the aim of protecting users' freedom to change the software. The systematic pattern of such abuse occurs in the area of products for individuals to use, which is precisely where it is most unacceptable. Therefore, we have designed this version of the GPL to prohibit the practice for those products. If such problems arise substantially in other domains, we stand ready to extend this provision to those domains in future versions of the GPL, as needed to protect the freedom of users.

Finally, every program is threatened constantly by software patents. States should not allow patents to restrict

development and use of software on general-purpose computers, but in those that do, we wish to avoid the special danger that patents applied to a free program could make it effectively proprietary. To prevent this, the GPL assures that patents cannot be used to render the program non-free.

The precise terms and conditions for copying, distribution and modification follow.

## TERMS AND CONDITIONS

### 0. Definitions.

"This License" refers to version 3 of the GNU General Public License.

"Copyright" also means copyright-like laws that apply to other kinds of works, such as semiconductor masks.

"The Program" refers to any copyrightable work licensed under this License. Each licensee is addressed as "you". "Licensees" and "recipients" may be individuals or organizations.

To "modify" a work means to copy from or adapt all or part of the work in a fashion requiring copyright permission, other than the making of an exact copy. The resulting work is called a "modified version" of the earlier work or a work "based on" the earlier work.

A "covered work" means either the unmodified Program or a work based on the Program.

To "propagate" a work means to do anything with it that, without permission, would make you directly or secondarily liable for infringement under applicable copyright law, except executing it on a computer or modifying a private copy. Propagation includes copying, distribution (with or without modification), making available to the public, and in some countries other activities as well.

To "convey" a work means any kind of propagation that enables other parties to make or receive copies. Mere interaction with a user through a computer network, with no transfer of a copy, is not conveying.

An interactive user interface displays “Appropriate Legal Notices” to the extent that it includes a convenient and prominently visible feature that (1) displays an appropriate copyright notice, and (2) tells the user that there is no warranty for the work (except to the extent that warranties are provided), that licensees may convey the work under this License, and how to view a copy of this License. If the interface presents a list of user commands or options, such as a menu, a prominent item in the list meets this criterion.

### **1. Source Code.**

The “source code” for a work means the preferred form of the work for making modifications to it. “Object code” means any non-source form of a work.

A “Standard Interface” means an interface that either is an official standard defined by a recognized standards body, or, in the case of interfaces specified for a particular programming language, one that is widely used among developers working in that language.

The “System Libraries” of an executable work include anything, other than the work as a whole, that (a) is included in the normal form of packaging a Major Component, but which is not part of that Major Component, and (b) serves only to enable use of the work with that Major Component, or to implement a Standard Interface for which an implementation is available to the public in source code form. A “Major Component”, in this context, means a major essential component (kernel, window system, and so on) of the specific operating system (if any) on which the executable work runs, or a compiler used to produce the work, or an object code interpreter used to run it.

The “Corresponding Source” for a work in object code form means all the source code needed to generate, install, and (for an executable work) run the object code and to modify the work, including scripts to control those activities. However, it does not include the work’s System Libraries, or general-purpose tools or generally available free programs which are used unmodified in

performing those activities but which are not part of the work. For example, Corresponding Source includes interface definition files associated with source files for the work, and the source code for shared libraries and dynamically linked subprograms that the work is specifically designed to require, such as by intimate data communication or control flow between those subprograms and other parts of the work.

The Corresponding Source need not include anything that users can regenerate automatically from other parts of the Corresponding Source.

The Corresponding Source for a work in source code form is that same work.

### **2. Basic Permissions.**

All rights granted under this License are granted for the term of copyright on the Program, and are irrevocable provided the stated conditions are met. This License explicitly affirms your unlimited permission to run the unmodified Program. The output from running a covered work is covered by this License only if the output, given its content, constitutes a covered work. This License acknowledges your rights of fair use or other equivalent, as provided by copyright law.

You may make, run and propagate covered works that you do not convey, without conditions so long as your license otherwise remains in force. You may convey covered works to others for the sole purpose of having them make modifications exclusively for you, or provide you with facilities for running those works, provided that you comply with the terms of this License in conveying all material for which you do not control copyright. Those thus making or running the covered works for you must do so exclusively on your behalf, under your direction and control, on terms that prohibit them from making any copies of your copyrighted material outside their relationship with you.

Conveying under any other circumstances is permitted solely under the conditions stated below. Sublicensing is not allowed; section 10 makes it unnecessary.

### **3. Protecting Users' Legal Rights From Anti-Circumvention Law.**

No covered work shall be deemed part of an effective technological measure under any applicable law fulfilling obligations under article 11 of the WIPO copyright treaty adopted on 20 December 1996, or similar laws prohibiting or restricting circumvention of such measures.

When you convey a covered work, you waive any legal power to forbid circumvention of technological measures to the extent such circumvention is effected by exercising rights under this License with respect to the covered work, and you disclaim any intention to limit operation or modification of the work as a means of enforcing, against the work's users, your or third parties' legal rights to forbid circumvention of technological measures.

### **4. Conveying Verbatim Copies.**

You may convey verbatim copies of the Program's source code as you receive it, in any medium, provided that you conspicuously and appropriately publish on each copy an appropriate copyright notice; keep intact all notices stating that this License and any non-permissive terms added in accord with section 7 apply to the code; keep intact all notices of the absence of any warranty; and give all recipients a copy of this License along with the Program.

You may charge any price or no price for each copy that you convey, and you may offer support or warranty protection for a fee.

### **5. Conveying Modified Source Versions.**

You may convey a work based on the Program, or the modifications to produce it from the Program, in the form of source code under the terms of section 4, provided that you also meet all of these conditions:

- a) The work must carry prominent notices stating that you modified it, and giving a relevant date.
- b) The work must carry prominent notices stating that it is released under this License and any conditions added under section 7. This requirement modifies the requirement in section 4 to "keep intact all notices".

- c) You must license the entire work, as a whole, under this License to anyone who comes into possession of a copy. This License will therefore apply, along with any applicable section 7 additional terms, to the whole of the work, and all its parts, regardless of how they are packaged. This License gives no permission to license the work in any other way, but it does not invalidate such permission if you have separately received it.
- d) If the work has interactive user interfaces, each must display Appropriate Legal Notices; however, if the Program has interactive interfaces that do not display Appropriate Legal Notices, your work need not make them do so.

A compilation of a covered work with other separate and independent works, which are not by their nature extensions of the covered work, and which are not combined with it such as to form a larger program, in or on a volume of a storage or distribution medium, is called an "aggregate" if the compilation and its resulting copyright are not used to limit the access or legal rights of the compilation's users beyond what the individual works permit. Inclusion of a covered work in an aggregate does not cause this License to apply to the other parts of the aggregate.

### **6. Conveying Non-Source Forms.**

You may convey a covered work in object code form under the terms of sections 4 and 5, provided that you also convey the machine-readable Corresponding Source under the terms of this License, in one of these ways:

- a) Convey the object code in, or embodied in, a physical product (including a physical distribution medium), accompanied by the Corresponding Source fixed on a durable physical medium customarily used for software interchange.
- b) Convey the object code in, or embodied in, a physical product (including a physical distribution medium), accompanied by a written offer, valid for at least three years and valid for as long as you offer spare parts or customer support for that product

model, to give anyone who possesses the object code either (1) a copy of the Corresponding Source for all the software in the product that is covered by this License, on a durable physical medium customarily used for software interchange, for a price no more than your reasonable cost of physically performing this conveying of source, or (2) access to copy the Corresponding Source from a network server at no charge.

- c) Convey individual copies of the object code with a copy of the written offer to provide the corresponding Source. This alternative is allowed only occasionally and noncommercially, and only if you received the object code with such an offer, in accord with subsection 6b.
- d) Convey the object code by offering access from a designated place (gratis or for a charge), and offer equivalent access to the Corresponding Source in the same way through the same place at no further charge. You need not require recipients to copy the Corresponding Source along with the object code. If the place to copy the object code is a network server, the Corresponding Source may be on a different server (operated by you or a third party) that supports equivalent copying facilities, provided you maintain clear directions next to the object code saying where to find the Corresponding Source. Regardless of what server hosts the Corresponding Source, you remain obligated to ensure that it is available for as long as needed to satisfy these requirements.
- e) Convey the object code using peer-to-peer transmission, provided you inform other peers where the object code and Corresponding Source of the work are being offered to the general public at no charge under subsection 6d.

A separable portion of the object code, whose source code is excluded from the Corresponding Source as a System Library, need not be included in conveying the object code work.

A "User Product" is either (1) a "consumer product", which means any tangible personal property which is normally used for personal, family, or household purposes, or (2) anything designed or sold for incorporation into a dwelling. In determining whether a product is a consumer product, doubtful cases shall be resolved in favor of coverage. For a particular product received by a particular user, "normally used" refers to a typical or common use of that class of product, regardless of the status of the particular user or of the way in which the particular user actually uses, or expects or is expected to use, the product. A product is a consumer product regardless of whether the product has substantial commercial, industrial or non-consumer uses, unless such uses represent the only significant mode of use of the product.

"Installation Information" for a User Product means any methods, procedures, authorization keys, or other information required to install and execute modified versions of a covered work in that User Product from a modified version of its Corresponding Source. The information must suffice to ensure that the continued functioning of the modified object code is in no case prevented or interfered with solely because modification has been made.

If you convey an object code work under this section in, or with, or specifically for use in, a User Product, and the conveying occurs as part of a transaction in which the right of possession and use of the User Product is transferred to the recipient in perpetuity or for a fixed term (regardless of how the transaction is characterized), the Corresponding Source conveyed under this section must be accompanied by the Installation Information. But this requirement does not apply if neither you nor any third party retains the ability to install modified object code on the User Product (for example, the work has been installed in ROM).

The requirement to provide Installation Information does not include a requirement to continue to provide support service, warranty, or updates for a work that has been modified

or installed by the recipient, or for the User Product in which it has been modified or installed. Access to a network may be denied when the modification itself materially and adversely affects the operation of the network or violates the rules and protocols for communication across the network.

Corresponding Source conveyed, and Installation Information provided, in accord with this section must be in a format that is publicly documented (and with an implementation available to the public in source code form), and must require no special password or key for unpacking, reading or copying.

## 7. Additional Terms.

“Additional permissions” are terms that supplement the terms of this License by making exceptions from one or more of its conditions. Additional permissions that are applicable to the entire Program shall be treated as though they were included in this License, to the extent that they are valid under applicable law. If additional permissions apply only to part of the Program, that part may be used separately under those permissions, but the entire Program remains governed by this License without regard to the additional permissions.

When you convey a copy of a covered work, you may at your option remove any additional permissions from that copy, or from any part of it. (Additional permissions may be written to require their own removal in certain cases when you modify the work.) You may place additional permissions on material, added by you to a covered work, for which you have or can give appropriate copyright permission.

Notwithstanding any other provision of this License, for material you add to a covered work, you may (if authorized by the copyright holders of that material) supplement the terms of this License with terms:

- a) Disclaiming warranty or limiting liability differently from the terms of sections 15 and 16 of this License; or
- b) Requiring preservation of specified reasonable legal notices or author attributions in that material or in the Appropriate Legal Notices displayed by

works containing it; or

- c) Prohibiting misrepresentation of the origin of that material, or requiring that modified versions of such material be marked in reasonable ways as different from the original version; or
- d) Limiting the use for publicity purposes of names of licensors or authors of the material; or
- e) Declining to grant rights under trademark law for use of some trade names, trademarks, or service marks; or
- f) Requiring indemnification of licensors and authors of that material by anyone who conveys the material (or modified versions of it) with contractual assumptions of liability to the recipient, for any liability that these contractual assumptions directly impose on those licensors and authors.

All other non-permissive additional terms are considered “further restrictions” within the meaning of section 10. If the Program as you received it, or any part of it, contains a notice stating that it is governed by this License along with a term that is a further restriction, you may remove that term. If a license document contains a further restriction but permits relicensing or conveying under this License, you may add to a covered work material governed by the terms of that license document, provided that the further restriction does not survive such relicensing or conveying.

If you add terms to a covered work in accord with this section, you must place, in the relevant source files, a statement of the additional terms that apply to those files, or a notice indicating where to find the applicable terms.

Additional terms, permissive or non-permissive, may be stated in the form of a separately written license, or stated as exceptions; the above requirements apply either way.

## 8. Termination.

You may not propagate or modify a covered work except as expressly provided under this License. Any attempt otherwise to propagate

or modify it is void, and will automatically terminate your rights under this License (including any patent licenses granted under the third paragraph of section 11).

However, if you cease all violation of this License, then your license from a particular copyright holder is reinstated (a) provisionally, unless and until the copyright holder explicitly and finally terminates your license, and (b) permanently, if the copyright holder fails to notify you of the violation by some reasonable means prior to 60 days after the cessation.

Moreover, your license from a particular copyright holder is reinstated permanently if the copyright holder notifies you of the violation by some reasonable means, this is the first time you have received notice of violation of this License (for any work) from that copyright holder, and you cure the violation prior to 30 days after your receipt of the notice.

Termination of your rights under this section does not terminate the licenses of parties who have received copies or rights from you under this License. If your rights have been terminated and not permanently reinstated, you do not qualify to receive new licenses for the same material under section 10.

## **9. Acceptance Not Required for Having Copies.**

You are not required to accept this License in order to receive or run a copy of the Program. Ancillary propagation of a covered work occurring solely as a consequence of using peer-to-peer transmission to receive a copy likewise does not require acceptance. However, nothing other than this License grants you permission to propagate or modify any covered work. These actions infringe copyright if you do not accept this License. Therefore, by modifying or propagating a covered work, you indicate your acceptance of this License to do so.

## **10. Automatic Licensing of Downstream Recipients.**

Each time you convey a covered work, the recipient automatically receives a license

from the original licensors, to run, modify and propagate that work, subject to this License. You are not responsible for enforcing compliance by third parties with this License.

An “entity transaction” is a transaction transferring control of an organization, or substantially all assets of one, or subdividing an organization, or merging organizations. If propagation of a covered work results from an entity transaction, each party to that transaction who receives a copy of the work also receives whatever licenses to the work the party's predecessor in interest had or could give under the previous paragraph, plus a right to possession of the Corresponding Source of the work from the predecessor in interest, if the predecessor has it or can get it with reasonable efforts.

You may not impose any further restrictions on the exercise of the rights granted or affirmed under this License. For example, you may not impose a license fee, royalty, or other charge for exercise of rights granted under this License, and you may not initiate litigation (including a cross-claim or counterclaim in a lawsuit) alleging that any patent claim is infringed by making, using, selling, offering for sale, or importing the Program or any portion of it.

## **11. Patents.**

A “contributor” is a copyright holder who authorizes use under this License of the Program or a work on which the Program is based. The work thus licensed is called the contributor's “contributor version”.

A contributor's “essential patent claims” are all patent claims owned or controlled by the contributor, whether already acquired or hereafter acquired, that would be infringed by some manner, permitted by this License, of making, using, or selling its contributor version, but do not include claims that would be infringed only as a consequence of further modification of the contributor version. For purposes of this definition, “control” includes the right to grant patent sublicenses in a manner consistent with the requirements of this License.

Each contributor grants you a non-exclusive, worldwide, royalty-free patent license under the contributor's essential patent claims, to make, use, sell, offer for sale, import and otherwise run, modify and propagate the contents of its contributor version.

In the following three paragraphs, a "patent license" is any express agreement or commitment, however denominated, not to enforce a patent (such as an express permission to practice a patent or covenant not to sue for patent infringement). To "grant" such a patent license to a party means to make such an agreement or commitment not to enforce a patent against the party.

If you convey a covered work, knowingly relying on a patent license, and the Corresponding Source of the work is not available for anyone to copy, free of charge and under the terms of this License, through a publicly available network server or other readily accessible means, then you must either (1) cause the Corresponding Source to be so available, or (2) arrange to deprive yourself of the benefit of the patent license for this particular work, or (3) arrange, in a manner consistent with the requirements of this License, to extend the patent license to downstream recipients. "Knowingly relying" means you have actual knowledge that, but for the patent license, your conveying the covered work in a country, or your recipient's use of the covered work in a country, would infringe one or more identifiable patents in that country that you have reason to believe are valid.

If, pursuant to or in connection with a single transaction or arrangement, you convey, or propagate by procuring conveyance of, a covered work, and grant a patent license to some of the parties receiving the covered work authorizing them to use, propagate, modify or convey a specific copy of the covered work, then the patent license you grant is automatically extended to all recipients of the covered work and works based on it.

A patent license is "discriminatory" if it does not include within the scope of its coverage,

prohibits the exercise of, or is conditioned on the non-exercise of one or more of the rights that are specifically granted under this License. You may not convey a covered work if you are a party to an arrangement with a third party that is in the business of distributing software, under which you make payment to the third party based on the extent of your activity of conveying the work, and under which the third party grants, to any of the parties who would receive the covered work from you, a discriminatory patent license

- (a) in connection with copies of the covered work conveyed by you (or copies made from those copies), or
- (b) primarily for and in connection with specific products or compilations that contain the covered work, unless you entered into that arrangement, or that patent license was granted, prior to 28 March 2007.

Nothing in this License shall be construed as excluding or limiting any implied license or other defenses to infringement that may otherwise be available to you under applicable patent law.

## **12. No Surrender of Others' Freedom.**

If conditions are imposed on you (whether by court order, agreement or otherwise) that contradict the conditions of this License, they do not excuse you from the conditions of this License. If you cannot convey a covered work so as to satisfy simultaneously your obligations under this License and any other pertinent obligations, then as a consequence you may not convey it at all. For example, if you agree to terms that obligate you to collect a royalty for further conveying from those to whom you convey the Program, the only way you could satisfy both those terms and this License would be to refrain entirely from conveying the Program.

## **13. Use with the GNU Affero General Public License.**

Notwithstanding any other provision of this License, you have permission to link or combine any covered work with a work licensed under version 3 of the GNU Affero General Public License into a single combined

work, and to convey the resulting work. The terms of this License will continue to apply to the part which is the covered work, but the special requirements of the GNU Affero General Public License, section 13, concerning interaction through a network will apply to the combination as such.

#### **14. Revised Versions of this License.**

The Free Software Foundation may publish revised and/ or new versions of the GNU General Public License from time to time. Such new versions will be similar in spirit to the present version, but may differ in detail to address new problems or concerns.

Each version is given a distinguishing version number. If the Program specifies that a certain numbered version of the GNU General Public License "or any later version" applies to it, you have the option of following the terms and conditions either of that numbered version or of any later version published by the Free Software Foundation. If the Program does not specify a version number of the GNU General Public License, you may choose any version ever published by the Free Software Foundation.

If the Program specifies that a proxy can decide which future versions of the GNU General Public License can be used, that proxy's public statement of acceptance of a version permanently authorizes you to choose that version for the Program.

Later license versions may give you additional or different permissions. However, no additional obligations are imposed on any author or copyright holder as a result of your choosing to follow a later version.

#### **15. Disclaimer of Warranty.**

THERE IS NO WARRANTY FOR THE PROGRAM, TO THE EXTENT PERMITTED BY APPLICABLE LAW. EXCEPT WHEN OTHERWISE STATED IN WRITING THE COPYRIGHT HOLDERS AND/OR OTHER PARTIES PROVIDE THE PROGRAM "AS IS" WITHOUT WARRANTY OF ANY KIND, EITHER EXPRESSED OR IMPLIED, INCLUDING, BUT NOT LIMITED

TO, THE IMPLIED WARRANTIES OF MERCHANTABILITY AND FITNESS FOR A PARTICULAR PURPOSE. THE ENTIRE RISK AS TO THE QUALITY AND PERFORMANCE OF THE PROGRAM IS WITH YOU. SHOULD THE PROGRAM PROVE DEFECTIVE, YOU ASSUME THE COST OF ALL NECESSARY SERVICING, REPAIR OR CORRECTION.

#### **16. Limitation of Liability.**

IN NO EVENT UNLESS REQUIRED BY APPLICABLE LAW OR AGREED TO IN WRITING WILL ANY COPYRIGHT HOLDER, OR ANY OTHER PARTY WHO MODIFIES AND/OR CONVEYS THE PROGRAM AS PERMITTED ABOVE, BE LIABLE TO YOU FOR DAMAGES, INCLUDING ANY GENERAL, SPECIAL, INCIDENTAL OR CONSEQUENTIAL DAMAGES ARISING OUT OF THE USE OR INABILITY TO USE THE PROGRAM (INCLUDING BUT NOT LIMITED TO LOSS OF DATA OR DATA BEING RENDERED INACCURATE OR LOSSES SUSTAINED BY YOU OR THIRD PARTIES OR A FAILURE OF THE PROGRAM TO OPERATE WITH ANY OTHER PROGRAMS), EVEN IF SUCH HOLDER OR OTHER PARTY HAS BEEN ADVISED OF THE POSSIBILITY OF SUCH DAMAGES.

#### **17. Interpretation of Sections 15 and 16.**

If the disclaimer of warranty and limitation of liability provided above cannot be given local legal effect according to their terms, reviewing courts shall apply local law that most closely approximates an absolute waiver of all civil liability in connection with the Program, unless a warranty or assumption of liability accompanies a copy of the Program in return for a fee.

## **END OF TERMS AND CONDITIONS**

### **GNU LESSER GENERAL PUBLIC LICENSE**

Version 2.1, February 1999

Copyright (C) 1991, 1999 Free Software Foundation, Inc. 51 Franklin Street, Fifth Floor, Boston, MA 02110-1301



USA Everyone is permitted to copy and distribute verbatim copies of this license document, but changing it is not allowed.

[This is the first released version of the Lesser GPL. It also counts as the successor of the GNU Library Public License, version 2, hence the version number 2.1.]

## Preamble

The licenses for most software are designed to take away your freedom to share and change it. By contrast, the GNU General Public Licenses are intended to guarantee your freedom to share and change free software to make sure the software is free for all its users.

This license, the Lesser General Public License, applies to some specially designated software packages—typically libraries—of the Free Software Foundation and other authors who decide to use it. You can use it too, but we suggest you first think carefully about whether this license or the ordinary General Public License is the better strategy to use in any particular case, based on the explanations below.

When we speak of free software, we are referring to freedom of use, not price. Our General Public Licenses are designed to make sure that you have the freedom to distribute copies of free software (and charge for this service if you wish); that you receive source code or can get it if you want it; that you can change the software and use pieces of it in new free programs; and that you are informed that you can do these things.

To protect your rights, we need to make restrictions that forbid distributors to deny you these rights or to ask you to surrender these rights. These restrictions translate to certain responsibilities for you if you distribute copies of the library or if you modify it.

For example, if you distribute copies of the library, whether gratis or for a fee, you must give the recipients all the rights that

we gave you. You must make sure that they, too, receive or can get the source code. If you link other code with the library, you must provide complete object files to the recipients, so that they can relink them with the library after making changes to the library and recompiling it. And you must show them these terms so they know their rights.

We protect your rights with a two-step method: (1) we copyright the library, and (2) we offer you this license, which gives you legal permission to copy, distribute and/or modify the library.

To protect each distributor, we want to make it very clear that there is no warranty for the free library. Also, if the library is modified by someone else and passed on, the recipients should know that what they have is not the original version, so that the original author's reputation will not be affected by problems that might be introduced by others.

Finally, software patents pose a constant threat to the existence of any free program. We wish to make sure that a company cannot effectively restrict the users of a free program by obtaining a restrictive license from a patent holder. Therefore, we insist that any patent license obtained for a version of the library must be consistent with the full freedom of use specified in this license.

Most GNU software, including some libraries, is covered by the ordinary GNU General Public License. This license, the GNU Lesser General Public License, applies to certain designated libraries, and is quite different from the ordinary General Public License. We use this license for certain libraries in order to permit linking those libraries into non-free programs.

When a program is linked with a library, whether statically or using a shared library, the combination of the two is legally speaking a combined work, a derivative of the original library. The ordinary General

Public License therefore permits such linking only if the entire combination fits its criteria of freedom. The Lesser General Public License permits more lax criteria for linking other code with the library.

We call this license the “Lesser” General Public License because it does Less to protect the user’s freedom than the ordinary General Public License. It also provides other free software developers Less of an advantage over competing non-free programs. These disadvantages are the reason we use the ordinary General Public License for many libraries. However, the Lesser license provides advantages in certain special circumstances.

For example, on rare occasions, there may be a special need to encourage the widest possible use of a certain library, so that it becomes a de-facto standard. To achieve this, non-free programs must be allowed to use the library. A more frequent case is that a free library does the same job as widely used non-free libraries. In this case, there is little to gain by limiting the free library to free software only, so we use the Lesser General Public License.

In other cases, permission to use a particular library in non-free programs enables a greater number of people to use a large body of free software. For example, permission to use the GNU C Library in non-free programs enables many more people to use the whole GNU operating system, as well as its variant, the GNU/Linux operating system.

Although the Lesser General Public License is Less protective of the users’ freedom, it does ensure that the user of a program that is linked with the Library has the freedom and the wherewithal to run that program using a modified version of the Library.

The precise terms and conditions for copying, distribution and modification follow. Pay close attention to the difference between a “work based on the library” and

a “work that uses the library”. The former contains code derived from the library, whereas the latter must be combined with the library in order to run.

## **TERMS AND CONDITIONS FOR COPYING, DISTRIBUTION AND MODIFICATION**

0. This License Agreement applies to any software library or other program which contains a notice placed by the copyright holder or other authorized party saying it may be distributed under the terms of this Lesser General Public License (also called “this License”). Each licensee is addressed as “you”.

A “library” means a collection of software functions and/ or data prepared so as to be conveniently linked with application programs (which use some of those functions and data) to form executables.

The “Library”, below, refers to any such software library or work which has been distributed under these terms. A “work based on the Library” means either the Library or any derivative work under copyright law: that is to say, a work containing the Library or a portion of it, either verbatim or with modifications and/or translated straightforwardly into another language. (Hereinafter, translation is included without limitation in the term “modification”.)

“Source code” for a work means the preferred form of the work for making modifications to it. For a library, complete source code means all the source code for all modules it contains, plus any associated interface definition files, plus the scripts used to control compilation and installation of the library.

Activities other than copying, distribution and modification are not covered by this License; they are outside its scope. The act of running a program using the Library is not restricted, and output from such a program

is covered only if its contents constitute a work based on the Library (independent of the use of the Library in a tool for writing it). Whether that is true depends on what the Library does and what the program that uses the Library does.

1. You may copy and distribute verbatim copies of the Library's complete source code as you receive it, in any medium, provided that you conspicuously and appropriately publish on each copy an appropriate copyright notice and disclaimer of warranty; keep intact all the notices that refer to this License and to the absence of any warranty; and distribute a copy of this License along with the Library.

You may charge a fee for the physical act of transferring a copy, and you may at your option offer warranty protection in exchange for a fee.

2. You may modify your copy or copies of the Library or any portion of it, thus forming a work based on the Library, and copy and distribute such modifications or work under the terms of Section 1 above, provided that you also meet all of these conditions:

a) The modified work must itself be a software library. b) You must cause the files modified to carry prominent notices stating that you changed the files and the date of any change. c) You must cause the whole of the work to be licensed at no charge to all third parties under the terms of this License. d) If a facility in the modified Library refers to a function or a table of data to be supplied by an application program that uses the facility, other than as an argument passed when the facility is invoked, then you must make a good faith effort to ensure that, in the event an application does not supply such function or table, the facility still operates, and performs whatever part of its purpose remains meaningful. (For example, a function in a library to compute square roots has a purpose that is entirely

well-defined independent of the application. Therefore, Subsection 2d requires that any application-supplied function or table used by this function must be optional: if the application does not supply it, the square root function must still compute square roots.) These requirements apply to the modified work as a whole. If identifiable sections of that work are not derived from the Library, and can be reasonably considered independent and separate works in themselves, then this License, and its terms, do not apply to those sections when you distribute them as separate works. But when you distribute the same sections as part of a whole which is a work based on the Library, the distribution of the whole must be on the terms of this License, whose permissions for other licensees extend to the entire whole, and thus to each and every part regardless of who wrote it.

Thus, it is not the intent of this section to claim rights or contest your rights to work written entirely by you; rather, the intent is to exercise the right to control the distribution of derivative or collective works based on the Library.

In addition, mere aggregation of another work not based on the Library with the Library (or with a work based on the Library) on a volume of a storage or distribution medium does not bring the other work under the scope of this License.

3. You may opt to apply the terms of the ordinary GNU General Public License instead of this License to a given copy of the Library. To do this, you must alter all the notices that refer to this License, so that they refer to the ordinary GNU General Public License, version 2, instead of to this License. (If a newer version than version 2 of the ordinary GNU General Public License has appeared, then you can specify that version instead if you wish.) Do not make any other change in these notices.

Once this change is made in a given copy,

it is irreversible for that copy, so the ordinary GNU General Public License applies to all subsequent copies and derivative works made from that copy.

This option is useful when you wish to copy part of the code of the Library into a program that is not a library.

4. You may copy and distribute the Library (or a portion or derivative of it, under Section 2) in object code or executable form under the terms of Sections 1 and 2 above provided that you accompany it with the complete corresponding machine-readable source code, which must be distributed under the terms of Sections 1 and 2 above on a medium customarily used for software interchange.

If distribution of object code is made by offering access to copy from a designated place, then offering equivalent access to copy the source code from the same place satisfies the requirement to distribute the source code, even though third parties are not compelled to copy the source along with the object code.

5. A program that contains no derivative of any portion of the Library, but is designed to work with the Library by being compiled or linked with it, is called a "work that uses the Library". Such a work, in isolation, is not a derivative work of the Library, and therefore falls outside the scope of this License.

However, linking a "work that uses the Library" with the Library creates an executable that is a derivative of the Library (because it contains portions of the Library), rather than a "work that uses the library". The executable is therefore covered by this License. Section 6 states terms for distribution of such executables.

When a "work that uses the Library" uses material from a header file that is part of the Library, the object code for the work may be a derivative work of the Library even

though the source code is not. Whether this is true is especially significant if the work can be linked without the Library, or if the work is itself a library. The threshold for this to be true is not precisely defined by law.

If such an object file uses only numerical parameters, data structure layouts and accessors, and small macros and small inline functions (ten lines or less in length), then the use of the object file is unrestricted, regardless of whether it is legally a derivative work. (Executables containing this object code plus portions of the Library will still fall under Section 6.)

Otherwise, if the work is a derivative of the Library, you may distribute the object code for the work under the terms of Section 6. Any executables containing that work also fall under Section 6, whether or not they are linked directly with the Library itself.

6. As an exception to the Sections above, you may also combine or link a "work that uses the Library" with the Library to produce a work containing portions of the Library, and distribute that work under terms of your choice, provided that the terms permit modification of the work for the customer's own use and reverse engineering for debugging such modifications.

You must give prominent notice with each copy of the work that the Library is used in it and that the Library and its use are covered by this License. You must supply a copy of this License. If the work during execution displays copyright notices, you must include the copyright notice for the Library among them, as well as a reference directing the user to the copy of this License. Also, you must do one of these things:

a) Accompany the work with the complete corresponding machine-readable source code for the Library including whatever changes were used in the work (which must be distributed under Sections

1 and 2 above); and, if the work is an executable linked with the Library, with the complete machine readable “work that uses the Library”, as object code and/or source code, so that the user can modify the Library and then relink to produce a modified executable containing the modified Library. (It is understood that the user who changes the contents of definitions files in the Library will not necessarily be able to recompile the application to use the modified definitions.)

b) Use a suitable shared library mechanism for linking with the Library. A suitable mechanism is one that

(1) uses at run time a copy of the library already present on the user's computer system, rather than copying library functions into the executable, and (2) will operate properly with a modified version of the library, if the user installs one, as long as the modified version is interface-compatible with the version that the work was made with.

c) Accompany the work with a written offer, valid for at least three years, to give the same user the materials specified in Subsection 6a, above, for a charge no more than the cost of performing this distribution.

d) If distribution of the work is made by offering access to copy from a designated place, offer equivalent access to copy the above specified materials from the same place.

e) Verify that the user has already received a copy of these materials or that you have already sent this user a copy.

For an executable, the required form of the “work that uses the Library” must include any data and utility programs needed for reproducing the executable from it. However, as a special exception, the materials to be distributed need not include anything that is normally distributed (in

either source or binary form) with the major components (compiler, kernel, and so on) of the operating system on which the executable runs, unless that component itself accompanies the executable.

It may happen that this requirement contradicts the license restrictions of other proprietary libraries that do not normally accompany the operating system. Such a contradiction means you cannot use both them and the Library together in an executable that you distribute.

7. You may place library facilities that are a work based on the Library side-by-side in a single library together with other library facilities not covered by this License, and distribute such a combined library, provided that the separate distribution of the work based on the Library and of the other library facilities is otherwise permitted, and provided that you do these two things:

a) Accompany the combined library with a copy of the same work based on the Library, uncombined with any other library facilities. This must be distributed under the terms of the Sections above.

b) Give prominent notice with the combined library of the fact that part of it is a work based on the Library, and explaining where to find the accompanying uncombined form of the same work.

8. You may not copy, modify, sublicense, link with, or distribute the Library except as expressly provided under this License. Any attempt otherwise to copy, modify, sublicense, link with, or distribute the Library is void, and will automatically terminate your rights under this License. However, parties who have received copies, or rights, from you under this License will not have their licenses terminated so long as such parties remain in full compliance.

9. You are not required to accept this License, since you have not signed

it. However, nothing else grants you permission to modify or distribute the Library or its derivative works. These actions are prohibited by law if you do not accept this License. Therefore, by modifying or distributing the Library (or any work based on the Library), you indicate your acceptance of this License to do so, and all its terms and conditions for copying, distributing or modifying the Library or works based on it.

10. Each time you redistribute the Library (or any work based on the Library), the recipient automatically receives a license from the original licensor to copy, distribute, link with or modify the Library subject to these terms and conditions. You may not impose any further restrictions on the recipients' exercise of the rights granted herein. You are not responsible for enforcing compliance by third parties with this License.
11. If, as a consequence of a court judgment or allegation of patent infringement or for any other reason (not limited to patent issues), conditions are imposed on you (whether by court order, agreement or otherwise) that contradict the conditions of this License, they do not excuse you from the conditions of this License. If you cannot distribute so as to satisfy simultaneously your obligations under this License and any other pertinent obligations, then as a consequence you may not distribute the Library at all. For example, if a patent license would not permit royalty free redistribution of the Library by all those who receive copies directly or indirectly through you, then the only way you could satisfy both it and this License would be to refrain entirely from distribution of the Library.

If any portion of this section is held invalid or unenforceable under any particular circumstance, the balance of the section

is intended to apply, and the section as a whole is intended to apply in other circumstances.

It is not the purpose of this section to induce you to infringe any patents or other property right claims or to contest validity of any such claims; this section has the sole purpose of protecting the integrity of the free software distribution system which is implemented by public license practices. Many people have made generous contributions to the wide range of software distributed through that system in reliance on consistent application of that system; it is up to the author/donor to decide if he or she is willing to distribute software through any other system and a licensee cannot impose that choice.

This section is intended to make thoroughly clear what is believed to be a consequence of the rest of this License.

12. If the distribution and/or use of the Library is restricted in certain countries either by patents or by copyrighted interfaces, the original copyright holder who places the Library under this License may add an explicit geographical distribution limitation excluding those countries, so that distribution is permitted only in or among countries not thus excluded. In such case, this License incorporates the limitation as if written in the body of this License.

13. The Free Software Foundation may publish revised and/or new versions of the Lesser General Public License from time to time. Such new versions will be similar in spirit to the present version, but may differ in detail to address new problems or concerns.

Each version is given a distinguishing version number. If the Library specifies a version number of this License which applies to it and "any later version", you have the option of following the terms and conditions either of that version or of any

later version published by the Free Software Foundation. If the Library does not specify a license version number, you may choose any version ever published by the Free Software Foundation.

14. If you wish to incorporate parts of the Library into other free programs whose distribution conditions are incompatible with these, write to the author to ask for permission. For software which is copyrighted by the Free Software Foundation, write to the Free Software Foundation; we sometimes make exceptions for this. Our decision will be guided by the two goals of preserving the free status of all derivatives of our free software and of promoting the sharing and reuse of software generally.

## **NO WARRANTY**

15. BECAUSE THE LIBRARY IS LICENSED FREE OF CHARGE, THERE IS NO WARRANTY FOR THE LIBRARY, TO THE EXTENT PERMITTED BY APPLICABLE LAW. EXCEPT WHEN OTHERWISE STATED IN WRITING THE COPYRIGHT HOLDERS AND/OR OTHER PARTIES PROVIDE THE LIBRARY "AS IS" WITHOUT WARRANTY OF ANY KIND, EITHER EXPRESSED OR IMPLIED, INCLUDING, BUT NOT LIMITED TO, THE IMPLIED WARRANTIES OF MERCHANTABILITY AND FITNESS FOR A PARTICULAR PURPOSE. THE ENTIRE RISK AS TO THE QUALITY AND PERFORMANCE OF THE LIBRARY IS WITH YOU. SHOULD THE LIBRARY PROVE DEFECTIVE, YOU ASSUME THE COST OF ALL NECESSARY SERVICING, REPAIR OR CORRECTION.
16. IN NO EVENT UNLESS REQUIRED BY APPLICABLE LAW OR AGREED TO IN WRITING WILL ANY COPYRIGHT HOLDER, OR ANY OTHER PARTY WHO MAY MODIFY AND/OR REDISTRIBUTE THE LIBRARY AS

PERMITTED ABOVE, BE LIABLE TO YOU FOR DAMAGES, INCLUDING ANY GENERAL, SPECIAL, INCIDENTAL OR CONSEQUENTIAL DAMAGES ARISING OUT OF THE USE OR INABILITY TO USE THE LIBRARY (INCLUDING BUT NOT LIMITED TO LOSS OF DATA OR DATA BEING RENDERED INACCURATE OR LOSSES SUSTAINED BY YOU OR THIRD PARTIES OR A FAILURE OF THE LIBRARY TO OPERATE WITH ANY OTHER SOFTWARE), EVEN IF SUCH HOLDER OR OTHER PARTY HAS BEEN ADVISED OF THE POSSIBILITY OF SUCH DAMAGES.

## **END OF TERMS AND CONDITIONS**

### **How to Apply These Terms to Your New Libraries**

If you develop a new library, and you want it to be of the greatest possible use to the public, we recommend making it free software that everyone can redistribute and change. You can do so by permitting redistribution under these terms (or, alternatively, under the terms of the ordinary General Public License).

To apply these terms, attach the following notices to the library. It is safest to attach them to the start of each source file to most effectively convey the exclusion of warranty; and each file should have at least the "copyright" line and a pointer to where the full notice is found. one line to give the library's name and an idea of what it does.

Copyright (C) year name of author

This library is free software; you can redistribute it and/ or modify it under the terms of the GNU Lesser General Public License as published by the Free Software Foundation; either version 2.1 of the License, or (at your option) any later version.

This library is distributed in the hope that it will be useful, but WITHOUT ANY

WARRANTY; without even the implied warranty of MERCHANTABILITY or FITNESS FOR A PARTICULAR PURPOSE. See the GNU Lesser General Public License for more details.

You should have received a copy of the GNU Lesser General Public License along with this library; if not, write to the Free Software Foundation, Inc., 51 Franklin Street, Fifth Floor, Boston, MA 02110-1301 USA Also add information on how to contact you by electronic and paper mail.

You should also get your employer (if you work as a programmer) or your school, if any, to sign a "copyright disclaimer" for the library, if necessary. Here is a sample; alter the names:

Yoyodyne, Inc., hereby disclaims all copyright interest in the library 'Frob' (a library for tweaking knobs) written by James Random Hacker.

signature of Ty Coon, 1 April 1990 Ty Coon,  
President of Vice.

## OpenSSL LICENSE

Copyright (c) 1998-2006 The OpenSSL Project. All rights reserved. Redistribution and use in source and binary forms, with or without modification, are permitted provided that the following conditions are met:

1. Redistributions of source code must retain the above copyright notice, this list of conditions and the following disclaimer.
2. Redistributions in binary form must reproduce the above copyright notice, this list of conditions and the following disclaimer in the documentation and/or other materials provided with the distribution.
3. All advertising materials mentioning features or use of this software must display the following acknowledgment: "This product includes software developed by the OpenSSL Project for

use in the OpenSSL Toolkit. (<http://www.openssl.org/>)"

4. The names "OpenSSL Toolkit" and "OpenSSL Project" must not be used to endorse or promote products derived from this software without prior written permission. For written permission, please contact [openssl-core@openssl.org](mailto:openssl-core@openssl.org).
5. Products derived from this software may not be called "OpenSSL" nor may "OpenSSL" appear in their names without prior written permission of the OpenSSL Project.
6. Redistributions of any form whatsoever must retain the following acknowledgment: "This product includes software developed by the OpenSSL Project for use in the OpenSSL Toolkit (<http://www.openssl.org/>)"

THIS SOFTWARE IS PROVIDED BY THE  
OPENSSL PROJECT "AS IS" AND ANY  
EXPRESSED OR IMPLIED WARRANTIES,  
INCLUDING, BUT NOT LIMITED TO,  
THE IMPLIED WARRANTIES OF  
MERCHANTABILITY AND FITNESS FOR A  
PARTICULAR PURPOSE ARE DISCLAIMED.  
IN NO EVENT SHALL THE OPENSSL  
PROJECT OR ITS CONTRIBUTORS BE  
LIABLE FOR ANY DIRECT, INDIRECT,  
INCIDENTAL, SPECIAL, EXEMPLARY, OR  
CONSEQUENTIAL DAMAGES (INCLUDING,  
BUT NOT LIMITED TO, PROCUREMENT  
OF SUBSTITUTE GOODS OR SERVICES;  
LOSS OF USE, DATA, OR PROFITS; OR  
BUSINESS INTERRUPTION) HOWEVER  
CAUSED AND ON ANY THEORY OF  
LIABILITY, WHETHER IN CONTRACT,  
STRICT LIABILITY, OR TORT (INCLUDING  
NEGLIGENCE OR OTHERWISE) ARISING  
IN ANY WAY OUT OF THE USE OF THIS  
SOFTWARE, EVEN IF ADVISED OF THE  
POSSIBILITY OF SUCH DAMAGE. This  
product includes cryptographic software  
written by Eric Young ([ey@cryptsoft.com](mailto:ey@cryptsoft.com)).  
This product includes software written by  
Tim Hudson ([tjh@cryptsoft.com](mailto:tjh@cryptsoft.com)).



## Original SSLeay License

Copyright (C) 1995-1998 Eric Young (eay@cryptsoft.com) All rights reserved. This package is an SSL implementation written by Eric Young (eay@cryptsoft.com). The implementation was written so as to conform with Netscapes SSL. This library is free for commercial and non-commercial use as long as the following conditions are adhered to. The following conditions apply to all code found in this distribution, be it the RC4, RSA, lhash, DES, etc., code; not just the SSL code. The SSL documentation included with this distribution is covered by the same copyright terms except that the holder is Tim Hudson (tjh@cryptsoft.com).

Copyright remains Eric Young's, and as such any Copyright notices in the code are not to be removed. If this package is used in a product, Eric Young should be given attribution as the author of the parts of the library used. This can be in the form of a textual message at program startup or in documentation (online or textual) provided with the package. Redistribution and use in source and binary forms, with or without modification, are permitted provided that the following conditions are met:

1. Redistributions of source code must retain the copyright notice, this list of conditions and the following disclaimer.
2. Redistributions in binary form must reproduce the above copyright notice, this list of conditions and the following disclaimer in the documentation and/or other materials provided with the distribution.
3. All advertising materials mentioning features or use of this software must display the following acknowledgement: "This product includes cryptographic software written by Eric Young (eay@cryptsoft.com)" The word 'cryptographic' can be left out if the routines from the library being used are not cryptographic related :-).

4. If you include any Windows specific code (or a derivative thereof) from the apps directory (application code) you must include an acknowledgement: "This product includes software written by Tim Hudson (tjh@cryptsoft.com)"

THIS SOFTWARE IS PROVIDED BY ERIC YOUNG "AS IS" AND ANY EXPRESS OR IMPLIED WARRANTIES, INCLUDING, BUT NOT LIMITED TO, THE IMPLIED WARRANTIES OF MERCHANTABILITY AND FITNESS FOR A PARTICULAR PURPOSE ARE DISCLAIMED. IN NO EVENT SHALL THE AUTHOR OR CONTRIBUTORS BE LIABLE FOR ANY DIRECT, INDIRECT, INCIDENTAL, SPECIAL, EXEMPLARY, OR CONSEQUENTIAL DAMAGES (INCLUDING, BUT NOT LIMITED TO, PROCUREMENT OF SUBSTITUTE GOODS OR SERVICES; LOSS OF USE, DATA, OR PROFITS; OR BUSINESS INTERRUPTION) HOWEVER CAUSED AND ON ANY THEORY OF LIABILITY, WHETHER IN CONTRACT, STRICT LIABILITY, OR TORT (INCLUDING NEGLIGENCE OR OTHERWISE) ARISING IN ANY WAY OUT OF THE USE OF THIS SOFTWARE, EVEN IF ADVISED OF THE POSSIBILITY OF SUCH DAMAGE.

The licence and distribution terms for any publicly available version or derivative of this code cannot be changed. i.e. this code cannot simply be copied and put under another distribution licence [including the GNU Public Licence].



## SALES NETWORK

---

### **SAMSUNG TECHWIN CO., LTD.**

Samsungtechwin R&D Center, 701, Sampyeong-dong, Bundang-gu, Seongnam-si, Gyeonggi-do, Korea, 463-400  
TEL : +82-70-7147-8740~60 FAX : +82-31-8018-3745

### **SAMSUNG TECHWIN AMERICA Inc.**

100 Challenger Rd. Suite 700 Ridgefield Park, NJ 07660  
Toll Free : +1-877-213-1222 Direct : +1-201-325-6920  
Fax : +1-201-373-0124  
[www.samsungcctvusa.com](http://www.samsungcctvusa.com)

### **SAMSUNG TECHWIN EUROPE LTD.**

Samsung House, 1000 Hillswood Drive, Hillswood Business  
Park Chertsey, Surrey, UNITED KINGDOM KT16 OPS  
TEL : +44-1932-45-5300 FAX : +44-1932-45-5325

---

[www.samsungtechwin.com](http://www.samsungtechwin.com)  
[www.samsungsecurity.com](http://www.samsungsecurity.com)  
[www.samsungipolis.com](http://www.samsungipolis.com)